KNIGHT

IDEX

IDEX CORPORATION



UniTech Laundry Instruction Manual

TABLE OF CONTENTS

Specifications	3
Pre-Installation.....	4
Installation	
▶ Mounting	4
▶ General	5
▶ Signal Connections	6
Operation.....	7
Programming.....	8
Adding Pumps	16
Changing the Circuit Board	
▶ Procedures	17
▶ Jumper Settings	17
Parts Diagrams	
▶ Main Controller	18
▶ 800 Satellite	20
Pump Layout Diagram.....	21
Wiring Diagram.....	22
Declaration of Conformity	23
Warranty Information	24
Knight Locations	24



CAUTION: Wear protective clothing and eyewear when dispensing chemicals or other materials. Observe safety handling instructions (MSDS) of chemical mfrs.



CAUTION: To avoid severe or fatal shock, always disconnect main power when servicing the unit.



CAUTION: When installing any equipment, ensure that all national and local safety, electrical, and plumbing codes are met.

SPECIFICATIONS

Parameters	Default Value	Range
❶ Pass Code	0000	0 – 9, A – Z
Pump Flow Rates	0	0-99.9 Oz, 999.ml
System Mode	Signal	Signal, Drain, Relay
Formula #	1	1 to 20
Load Count Pump	2	1 to 8
❷ Load Counter	0	0 – 65536
Units of Measure	US	US, Metric, Imperial
Pump Delay Units	SEC	SEC, MIN
Wash Signal Lockout	Disabled	Disabled, Enabled
AFS Select	Disabled	Disabled, Enabled
System Lockout Time	0	0-100 min
AFS Mode	Micro	Micro, Chart
AFS Micro Time Div	1	1, 2, 5
Flush Mode	Disabled	Disabled, Enabled
Flush Time	0	0-100 sec
Drain Signal Polarity	Normal	Normal, Inverted
Washer Signal Qualify Time	1	1-100 sec
Calibrate Mode	Time	Time, Volume
Flush Flow Check Delay	5	0-100 sec
Formula Run Times/Volumes	0	0-255 sec, 0-999 ml, 0-99.9 oz
Formula Delay Times	0	0-255 sec or min
Formula Names	Formula ##	Alpha-numeric range

- ❶ Pass code does not change when clearing all programmed settings
- ❷ The load counter has its own menu to allow resetting back to zero

SAFETY SYMBOL EXPLANATIONS

Listed below are explanations of the safety symbols that appear either on the unit, in the instruction manual, or both. Please familiarize yourself with the meaning of each symbol.



GENERAL CAUTION: This symbol indicates a general safety caution.



SHOCK HAZARD: This symbol indicates that hazardous voltages are inside the enclosure.



READ MANUAL: This symbol indicates to read the manual for important instructions and procedures related to safety.

PRE-INSTALLATION

- (1) Check all applicable plumbing and electrical codes before installation. This will help to ensure that the system is installed in safe and suitable manner.
- (2) Get a wiring schematic of the washmachine (provided by the machine mfr or may be on the machine itself).
- (3) Check to make sure that all functions of the washmachine are operating properly. Including; card reader or timer, water solenoids, flush down valves, water level switch, machine motor, and drain valve.
- (4) Check the proposed location for a 115, 208, or 230 VAC power source.
- (5) Check voltage of all washmachine supply signals that will be used. Measure voltage between supply signal and signal common with a voltmeter. Do not check signal voltage between supply signal and case (earth) ground.
- (6) Measure the distance from chemical supply containers to pump housing, and from pump housing to injection point inside washmachine.

Before beginning the installation, make sure you have the following tools and materials ready...

- Flat and Phillips screwdrivers. One screwdriver needs to have a long (20 cm) shank to reach the bottom mounting screw on the dispenser.
- Drill and drill bits.
- Suitable wire for main power and signals (check local codes).
- Wire cutters, wire strippers, and pliers.
- Wire terminal connectors and a crimping tool.
- Voltmeter (or multi-meter).
- Dry wall inserts and mounting screws.
- Electrical tape.
- Chemical test kit.
- Dispenser accessory kit.

INSTALLATION — MOUNTING

- (1) Remove existing dispenser, if any.
- (2) Use the mounting bracket to mark where the holes need to be drilled. Drill the three holes.



- (3) Press in the dry wall anchors and mount the bracket.



- (4) Hang the dispenser and mark where the bottom hole goes. For UniTech systems with more than two pumps, mark the locations of the other mounting holes.



- (5) Drill remaining holes and press in final dry wall inserts. Do not install the unit on the wall yet.
- (6) If you are using an MFM remote control, mount it to the front of the washer where operators can easily access it. Secure it to the washer using provided mounting screws or Dual-Lock fastening strips (be sure to first clean the mounting surface as the adhesive will not stick to a dirty surface).

NOTE: Systems shipped from the factory will already have the MFM cable connected inside the control box. If adding an MFM to an existing system, connect the cable per the wiring diagram on page 22.

INSTALLATION — GENERAL

Ensure that all power sources are turned off before proceeding with the following steps.

- (1) Pull the power wires through the conduit.

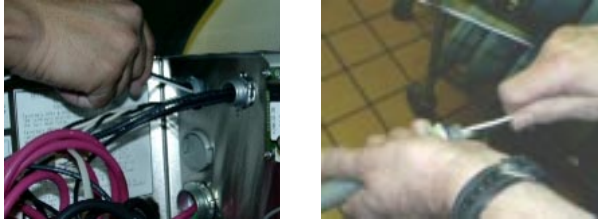

- (2) Remove the pump from the left side of the dispenser to make room. Remove knockout plug for the conduit by twisting with pliers.



- (3) Pull wires through the pump case and into the control box. Loosen the end of the conduit so that the male piece can freely rotate. Clearance is tight in the pump case, and you cannot easily rotate the conduit nut. Instead, hold the conduit nut with a wrench and rotate the male piece to tighten.



- (4) Disconnect the wiring harnesses to gain easier access to the wiring terminal strip. The terminal strip panel can be removed by loosening one screw (panel is slotted, the screw does not need to be removed). Slide the panel off the screw and lift out to access. Strip the power wires to ¼" bare ends and attach to the appropriate terminals on the strip. See wiring diagram (page 22) for further reference.

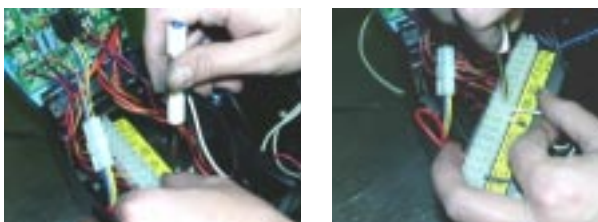

- (5) Re-attach the terminal strip and tighten the screw. Re-connect all wiring harnesses. Replace pump and attach faceplate.

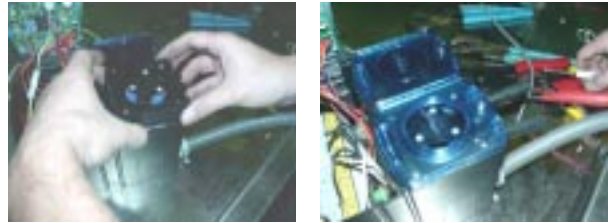

- (6) Hang the dispenser on the wall and install the final screw at the bottom of the dispenser. Use a long shank screwdriver to reach it. For UniTech systems with more than two pumps, install the remaining mounting screws.



- (7) For each pump, cut the suction tube to length and insert one end into the appropriate supply container using PVC pipe as a support. Insert other end of suction tube into the left (input) side of the pump's squeeze tube.
- (8) For each pump, cut the discharge tube to length and insert one end into the right (output) side of the pump's squeeze tube. Form an anti-siphon loop (pointing "down") with the other end of discharge tube and insert into the supply pocket of the machine.

NOTE: If using a flush manifold, the output side of the pump's squeeze tube will connect to the checkvalves on the manifold.

Powering Up

Upon power up, the display will sequence through all devices that are recognized, such as the satellite pumps, SIB, and MFM controller. If the display shows a pump that is not the correct size (for example: if an 800 pump is used, but the display shows that it's a 500) contact Knight for assistance.

INSTALLATION — SIGNALS / SIB

The SIB is a signal interface module that receives supply signals from the washer, then communicates with the dispenser to run the pumps. The low voltage cable connects the module to the pump system without requiring conduit.

NOTE: Systems shipped from the factory will already have the SIB properly connected. If a system in the field later has an MFM added, then the SIB will need to be connected directly to the MFM instead of the pump unit. See the wiring diagram on page 22 for details.

- (1) Mount the module using the provided Dual Lock adhesive strip. The module can be mounted inside the washer's controls, along side the washer's controls, or any other convenient location.
- (2) Connect the supply signals to the SIB per wire colors on the SIB label. If using Drain Mode, only one signal is required (pump #1).
- (3) If you have one signal common (typical) connect the common to "COM A" on the SIB. If you have two signal commons, you will need to remove a resistor inside the SIB before connecting the common wires! See the following details.

Splitting signal commons:

- (1) Remove the screws from the bottom of the SIB to open the module.
- (2) Locate the resistors on the right side of the module (each resistor has a single black band).
- (3) Cut and remove the resistor that will "split" the commons between the desired pumps. Be sure to remove only one resistor.

CUT RESISTOR	TO USE COM A FOR PUMPS	AND COM B FOR PUMPS
R19	1—2	3—8 (and AFS)
R20	1—3	4—8 (and AFS)
R17	1—4	5—8 (and AFS)
R15	1—5	6—8 (and AFS)
R16	1—6	7—8 (and AFS)
R18	1—7	8 (and AFS)
R21	1—8	AFS

- (4) Close the module and replace the screws when finished.

Low voltage signal filter

The SIB signal filtering capability can help prevent unwanted injections caused by stray signals or "bleed" voltages. Typically you will have only one signal common, however, if using "split commons", each common can be independently set to filter signals.

The signal filter is activated by removing a jumper wire inside the SIB. There is one jumper wire for common A and one for common B (if required). The diagram below shows the location of the jumper wires inside the SIB.

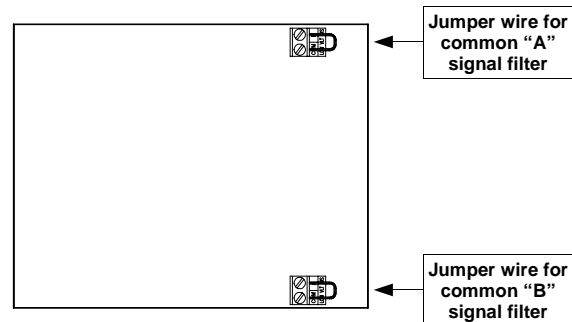

- When the jumper wire is removed, the signal input range is 70 – 240 volts.
- With the jumper wire in place (normal) the signal input range is 24 – 240 volts.
- Do not connect any signal wires or common wires to the terminals where the jumper wires go.

Follow the steps below to activate the signal filter. If you later need to setup the SIB for normal signal range, simply replace the jumper wires.

- (1) Remove all screws from the bottom of the SIB to open the module.
- (2) To filter signals that use common A, remove the jumper wire from the terminals in the upper left corner of the circuit board.
- (3) To filter signals that use common B (if required), remove the jumper wire from the terminals in the lower left corner of the circuit board.
- (4) Close the module and replace screws when finished.

OPERATION

The UniTech laundry system has three operating modes for maximum versatility with all types of washing machinery, and allowing you to choose the operation best suited for your application.

Signal Mode

The system is capable of up to 20 user selectable formulas with each formula having unique run times and delay times for each pump. The base unit holds a maximum of 8 formulas (and also if using the formula selector). The maximum of 20 formulas requires use of the MFM hand-held controller. Signals from the washer trigger the pumps, then the UniTech takes control to count down delay times and run times with up to 3 individual "levels" (explained below) for each pump. The machine operator, will select the formula using ↑ or ↓ buttons to choose the appropriate wash formula.

Programming "levels" allows a pump to inject different amounts of chemical for multiple signals to the same pump during a formula. For example, pump 1 could inject 8 ounces of chemical on its first signal, then later inject 12 ounces of chemical on its second signal. Up to three levels are available for any pump on any formula, except for the load count pump. Only 1 level can be programmed for the load count pump (and any other pump that may be signaled simultaneously with the load count pump's signal). The level feature can also be used to "skip over" an injection. Simply do not program any volume or delay time for that level.

One-to-one pump signal mode: When a formula begins the first signal to a pump will activate level 1. The signal has to be present for at least as long as the signal qualify time to be recognized. The second signal to the pump during the formula will activate level 2. The third signal to the pump during the formula will activate level 3. Any further signals will be disregarded once level 3 has been activated. The load count pump signal must be received to reset levels in preparation for the next formula.

Assigned pump signal mode: Each pump/formula/level combination has a signal assignment for which signal (to the SIB) will trigger the chemical injection. For example, pump 1 input on the SIB becomes "signal 1" and can be assigned to whatever pumps you wish to activate with this signal. Pump 2 input on the SIB becomes "signal 2", and so on. Incoming signals should be received by the UniTech in order from lowest number to highest number. This type of operation allows certain types of washer signals to be used more effectively to trigger chemical injections.

Drain Mode

This mode is similar to signal mode but requires only one signal source from the washer and works by counting the number of drains during a wash cycle. When programming UniTech for drain mode, each chemical pump is assigned a specific drain occurrence to inject product on. This feature only affects how the pumps are triggered – all other functions such as pump run times, delay times, and flush mode, will still operate normally.

During a wash formula, each drain signal is counted and the pumps inject chemical according to the drain number they are assigned. Drain mode is similar to signal mode, in that the pumps are programmed with run times (and delay times if necessary) and the flush mode works the same way it does in signal mode. Be sure to set the load count pump as the last pump to inject during a formula, and program a drain assignment for the load count pump on every formula used. If necessary, you can choose an unused pump number to be the load count pump.

The "multiple level" feature works slightly different in drain mode, because of the way drain mode counts the number of signals to pump #1 input. If a second injection level is required, it should be programmed to inject on a later drain number (occurrence) than the first level for that pump.

- During a formula, when pumps are idle, the display will show the current drain count and the formula name.
- Auto Formula Select is functional in drain mode, but not typically used (chart-type AFS is not recommended).
- Auto Formula Select (if used) resets drain count.

Relay Mode

This type of operation can be used with a microprocessor controlled washer. When set to relay mode, the UniTech system will run its pumps as long as their respective signals are present. There is a slight delay of a few seconds before the pump starts and stops running. The on and off delay are about equal, so there is no real need to adjust the signal duration for accurate dosing. To accomplish this, the system "by-passes" its run time and delay time capabilities for the chemical pumps, however flush mode still works the same way. Choosing a load count pump is optional in relay mode — load counts are tallied as a cumulative number and viewed in the typical manner.

BUTTON FUNCTION REFERENCE

- **ENTER:** Holding the enter button for 3 seconds (approx.) switches between run and program modes. Enter also advances through programming menus.
- **SCROLL:** The scroll button moves the position of the cursor in menus where text or number changes are done and toggles between choices in menus that have selectable settings. By pressing repeatedly, the cursor will “wrap around” at the end of a line of characters (advance to the beginning of the line automatically). The scroll button is also used to show load counts during normal operation. Press the button repeatedly to see load counts for individual formulas, then will show the total cumulative load count.
- **UP (↑):** Increases numeric values or advances upward through available characters. Hold the button down to rapidly advance. The UP button also chooses the formula during normal operation.
- **DOWN (↓):** Decreases numeric values or advances downward through available characters. Hold the button down to rapidly advance. The DOWN button also chooses the formula during normal operation.

PROGRAMMING

You may find it helpful to read through the programming instructions before getting started. This will better familiarize you with the operation of the UniTech, and will make the actual programming go much quicker.

Important Notes

- Be sure to clear all settings in base unit and MFM (if so equipped) before programming.
- If using an MFM, it is recommended to do all programming at the MFM keypad, rather than the base unit.
- If you wish to return to normal operating mode at any point during programming, hold down the ENTER button for 3 seconds to exit the programming mode.
- While programming, if no buttons are pressed for approximately 2 minutes, UniTech will automatically return to normal operating mode.

When you're ready to get started, hold down the ENTER button for about 3 seconds to go into the programming mode. Release the button when you see the access code prompt below...

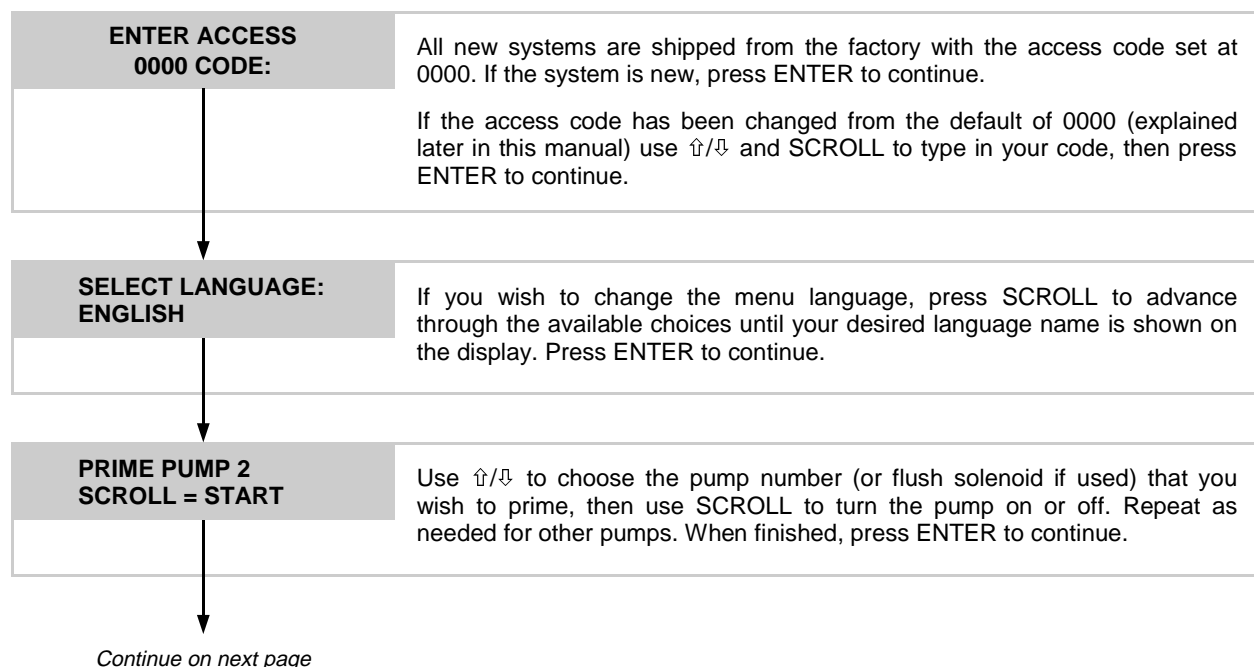

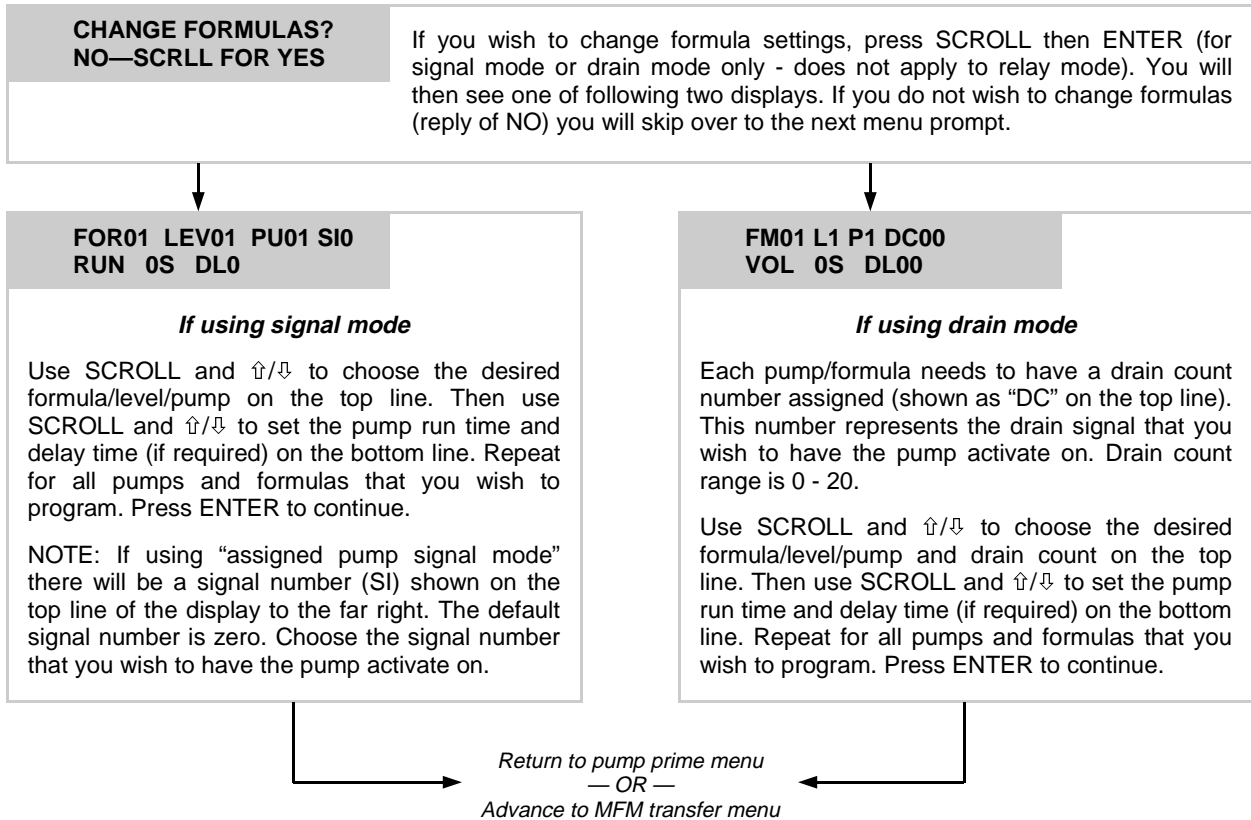

NOTES: For signal mode and drain mode formula programming.

- Press ENTER without changing any data if you wish to advance immediately to the MFM transfer menu.
- If pumps are calibrated in volume mode, the display will show “VOL” instead of “RUN”.
- Run time range: 0 - 255 seconds
- Delay time range is 0 - 255 seconds (or minutes)

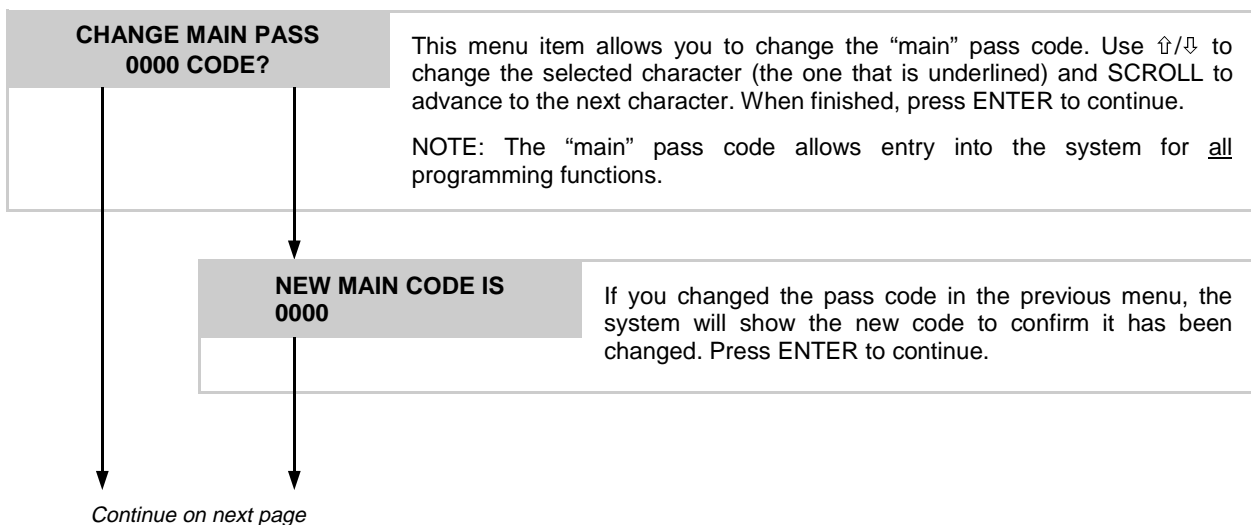

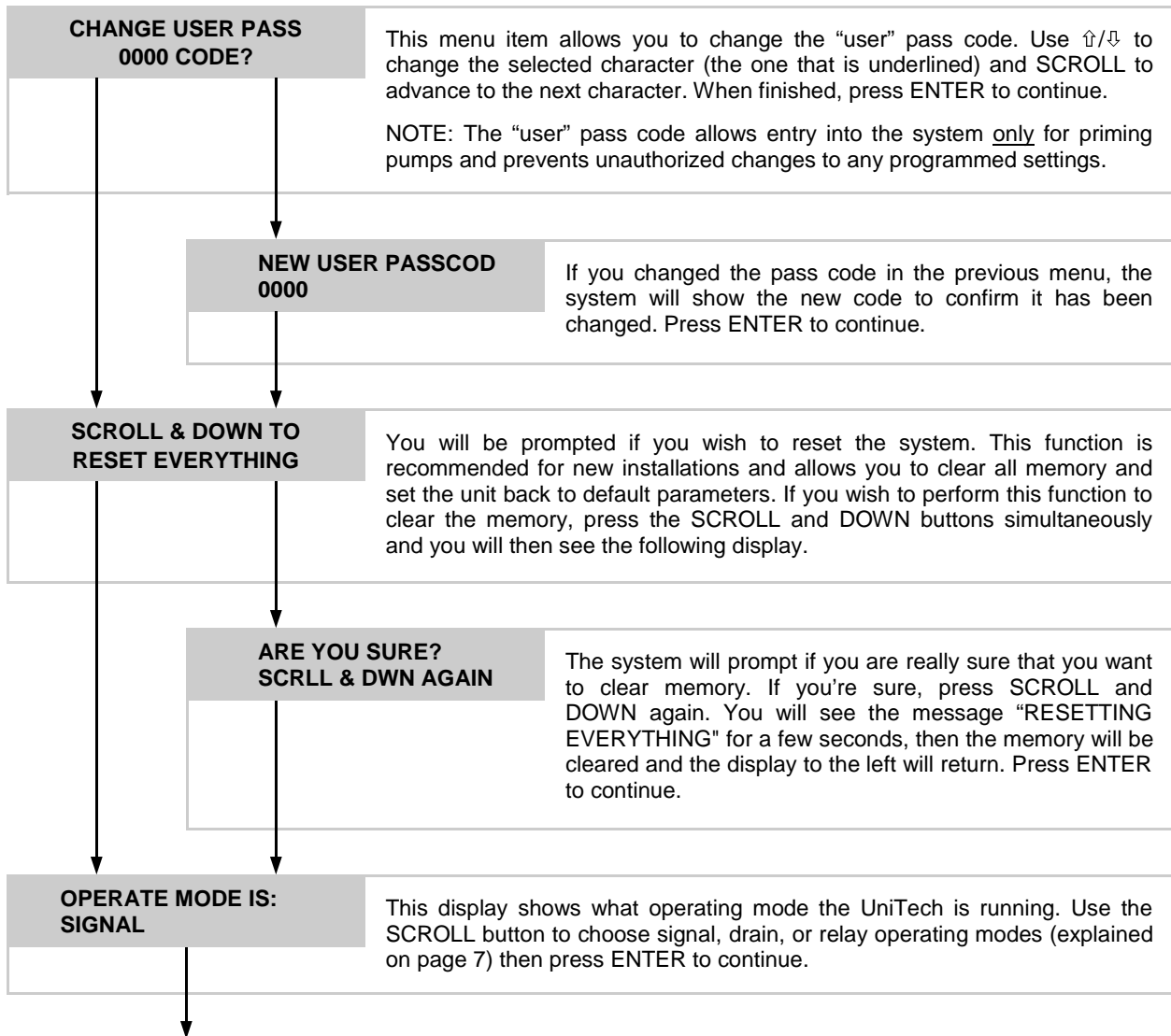

NOTE: If using relay mode, go to page 12 to continue (Main Controller menu prompt). Otherwise, you will see one of the following two displays, depending on which operating mode you selected.

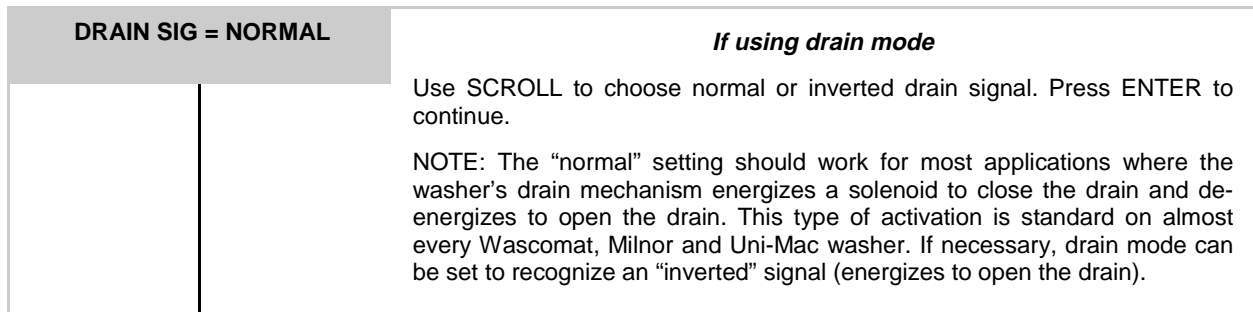

Continue on next page

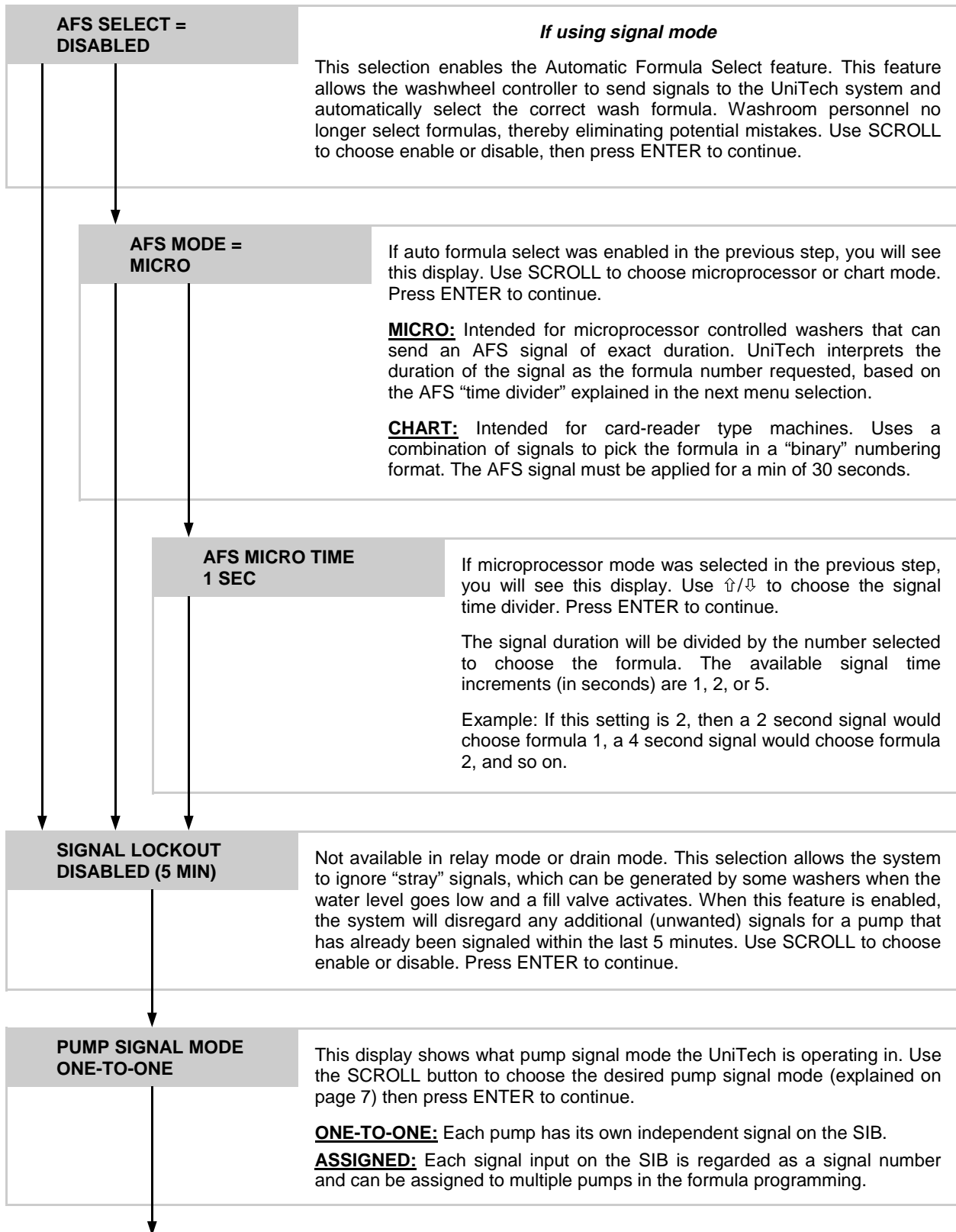

Continue on next page

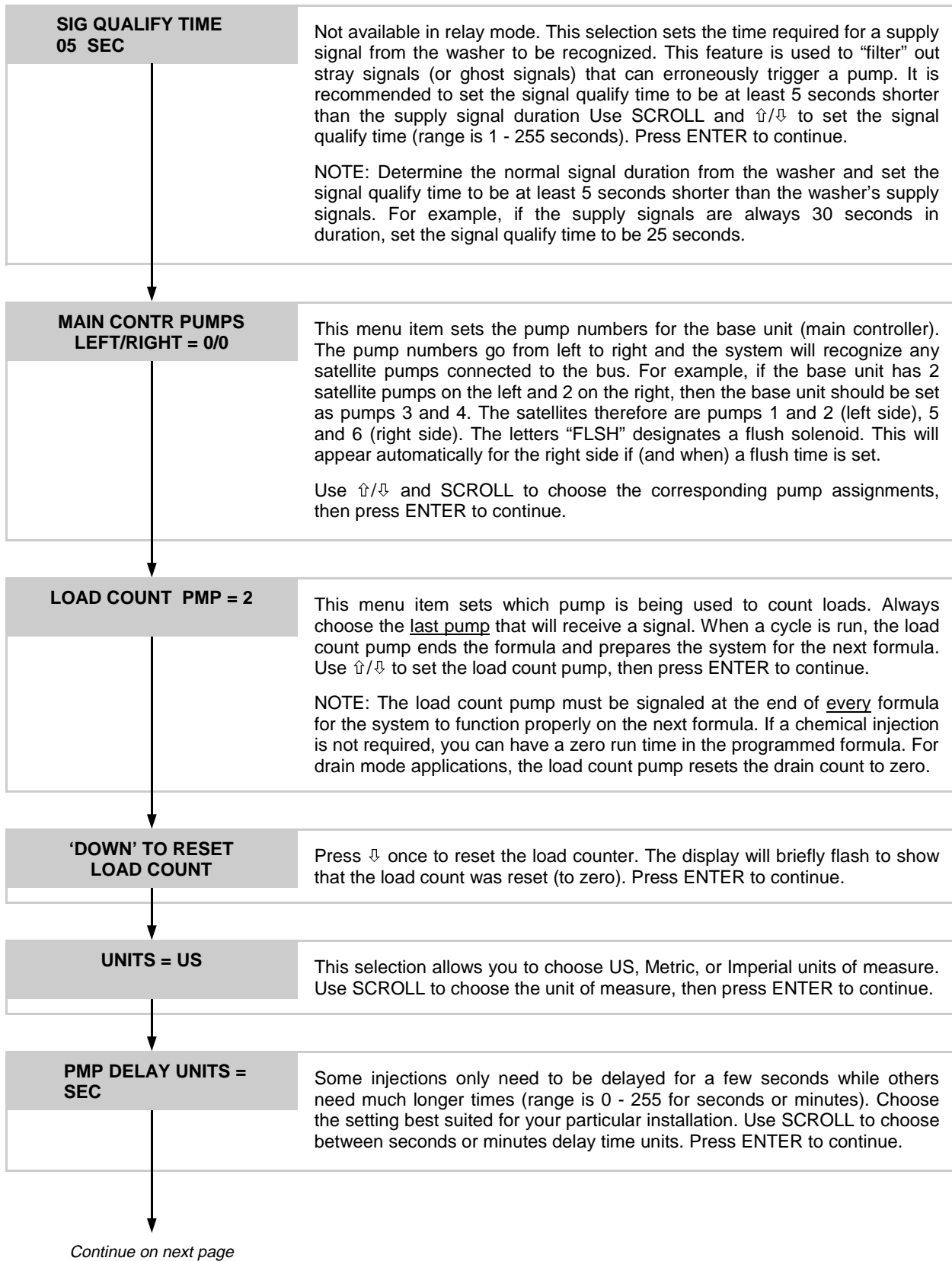

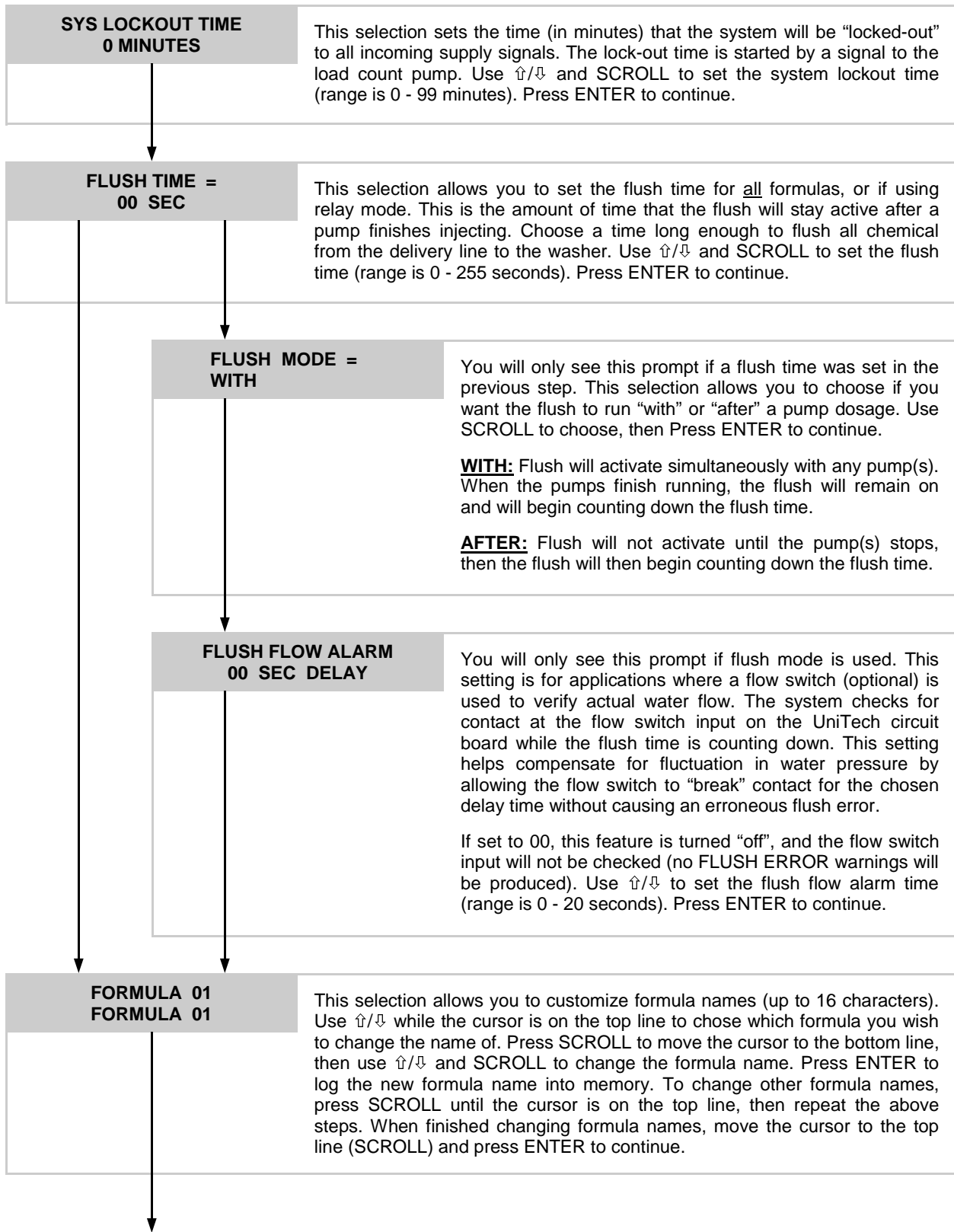

Continue on next page

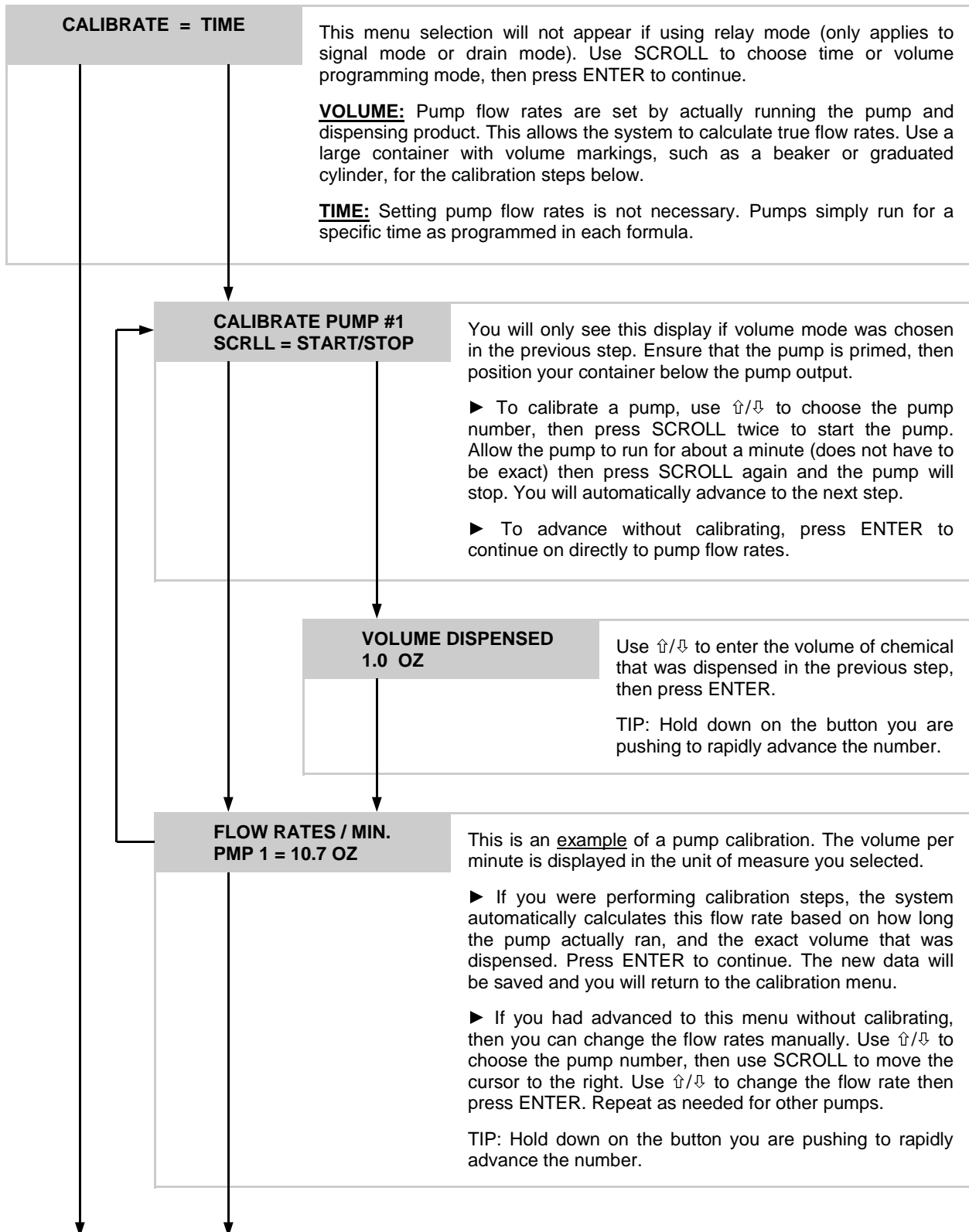

Continue on next page if using MFM
Return to first menu if programming at main controller

DATA TRANSFER FEATURE

NOTE: The following menus will only appear if programming at the MFM. If you are not using an MFM, and are programming at the base unit, the display will wrap around to the very first menu item (the beginning of the menus).

The MFM transfer function allows all programmed settings to be copied from one UniTech MFM to another through a MFM network cable (stereo jacks on both ends). All settings are copied from one MFM to the other, including the passcodes. You must choose (in the menus below) which MFM will send data, and which MFM will receive data. Both UniTech systems must be powered up and showing the menu prompt below in their display windows to continue.

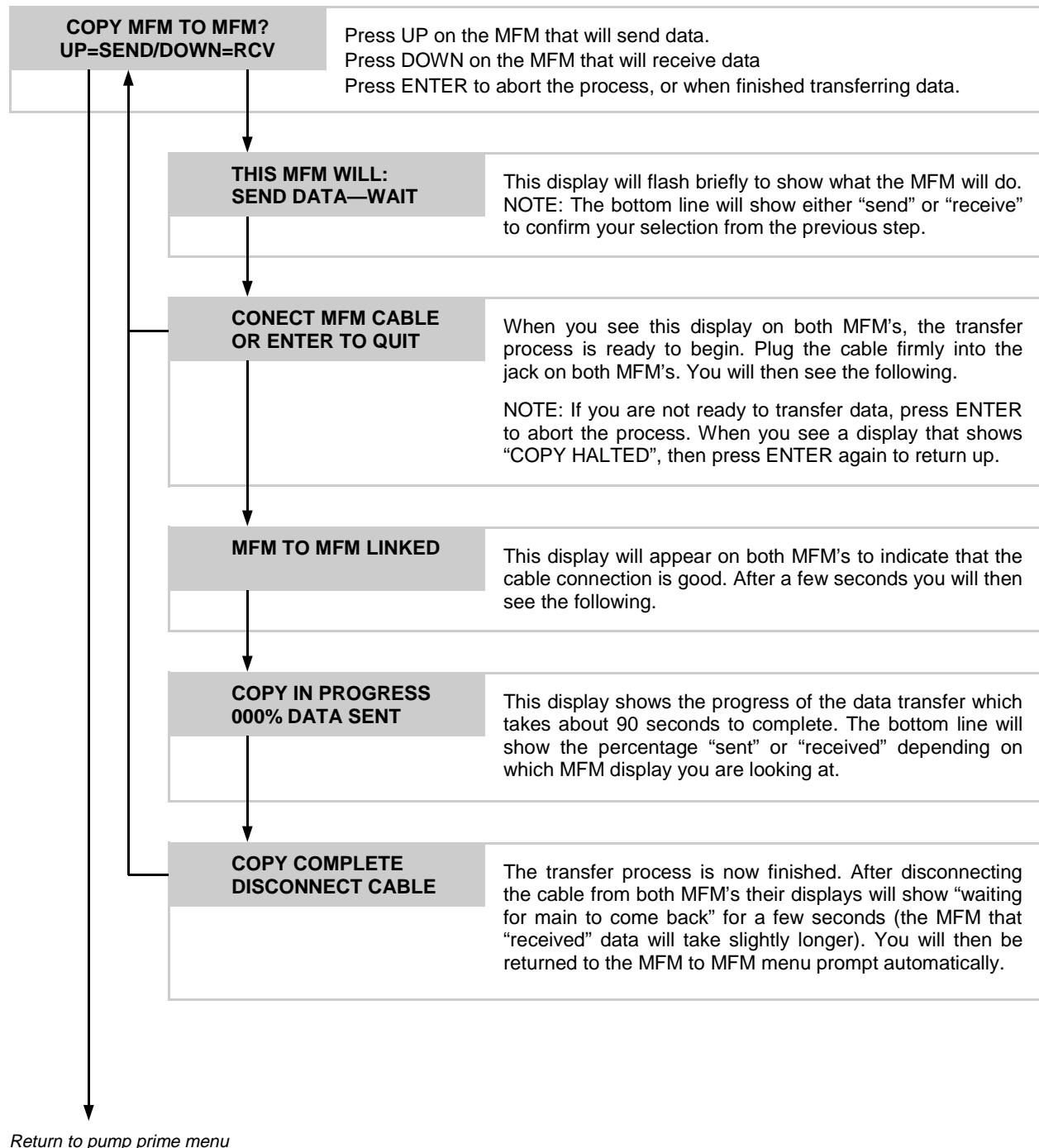

ADDING PUMPS

Adding a pump to an existing system requires just a few simple steps. The pump can be mounted on the right or left side of the UniTech dispenser.

- (1) Turn the unit over and lie it down, preferably on a smooth surface that won't scratch the display.
- (2) Remove the cover on the side of the unit by gently prying it up with a flat screwdriver tip.

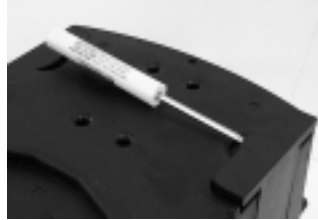

- (3) Line up the pump in the slot on the Uni-Tech. Ensure the 4-pin (bus) connectors are aligned and slowly slide the pump into place.



- (4) Insert the two provided screws and tighten.



- (5) Set the DIP switches (on the back of the pump) for what the new pump number will be. In the example below, the DIP switches are set so that the new pump will be pump #1.

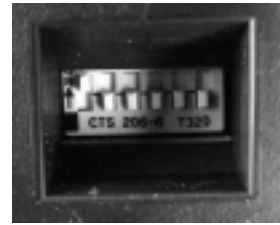

- (6) Repeat these steps for any other pumps to be added. Be sure to place the pump number stickers on the front and back sides of each pump added.



Display Shown on Power Up

When the UniTech dispenser is powered up for the first time after adding a pump (or pumps), the system will automatically check for new devices and the display will show all devices recognized.

**500 PMP Found
SubDevice #1**

This example shows that UniTech has recognized the new pump connected to the bus. The #1 indication simply means that this is the first "satellite" pump added to the unit. This message will appear briefly, then the system will automatically advance on to the normal display.

NOTE: The display will sequence through all devices that are recognized. If any new pumps do not appear in the display, check the DIP switch settings and the bus connection for proper engagement. If the display shows a pump that is not the correct size (for example: if an 800 pump is used, but the display shows that it's a 500) contact Knight for assistance.

CHANGING THE CIRCUIT BOARD

- (1) Ensure that power to the unit is off.
- (2) Loosen the two screws and swing the cover open.

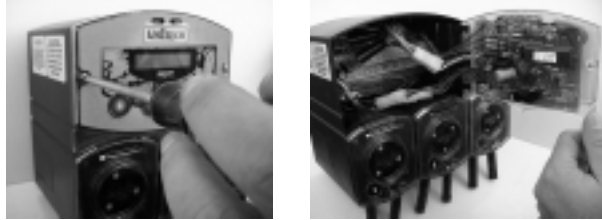

- (3) Remove mounting screw from the center of the circuit board. Disconnect wiring harnesses and all remaining wires that attach the circuit board to the terminal strip. Note the location of wires for later.

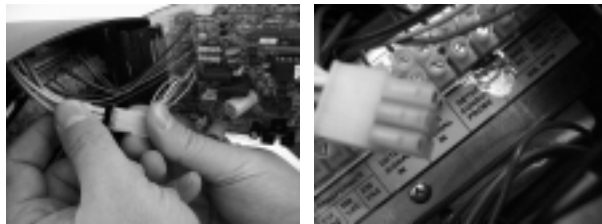

- (4) Gently push up on the two upper mounting tabs while pulling the circuit board away from the cover. Once the top is loose, the bottom will pull away freely from the lower tabs.



- (5) Replace with new circuit board and carefully line up the buttons and LED's with the holes on the cover. Snap the board into place on the upper and lower mounting tabs. Set the jumpers per table below.



- (6) Re-connect all wires to the terminal strip (that were disconnected in step 3) and re-connect the wiring harnesses. Replace the mounting screw.



- (7) Carefully tuck all wires in while closing the cover. Tighten the cover screws.



- (8) Process complete! Now ready to be powered up.

Jumper Settings

The circuit board has shunt jumpers that must be set for the type of UniTech system you have (diagram to the right shows jumper locations). This is particularly important when changing circuit boards so the new board will work correctly.

For UniTech laundry systems, always set the jumpers according to the table below.

JP1	JP2	JP3	JP4
OFF	OFF	ON	ON

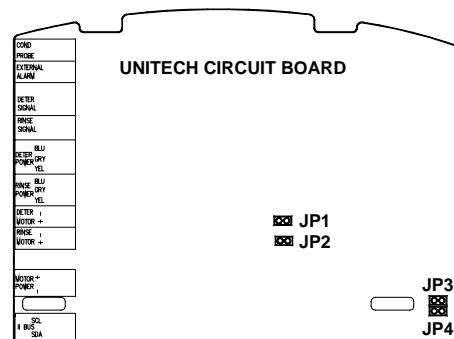

PARTS DIAGRAM — MAIN CONTROLLER

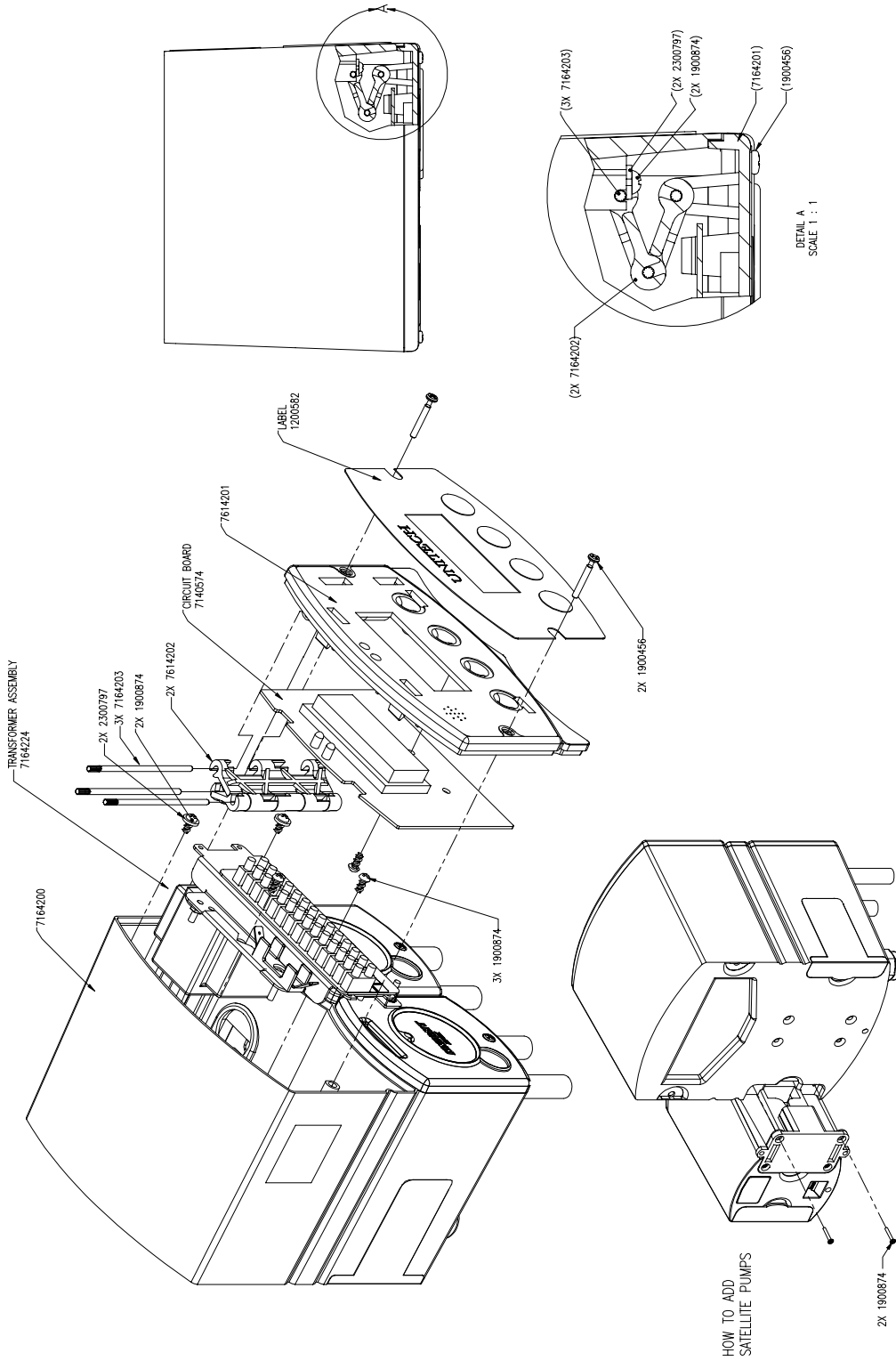

PARTS DIAGRAM — MAIN CONTROLLER

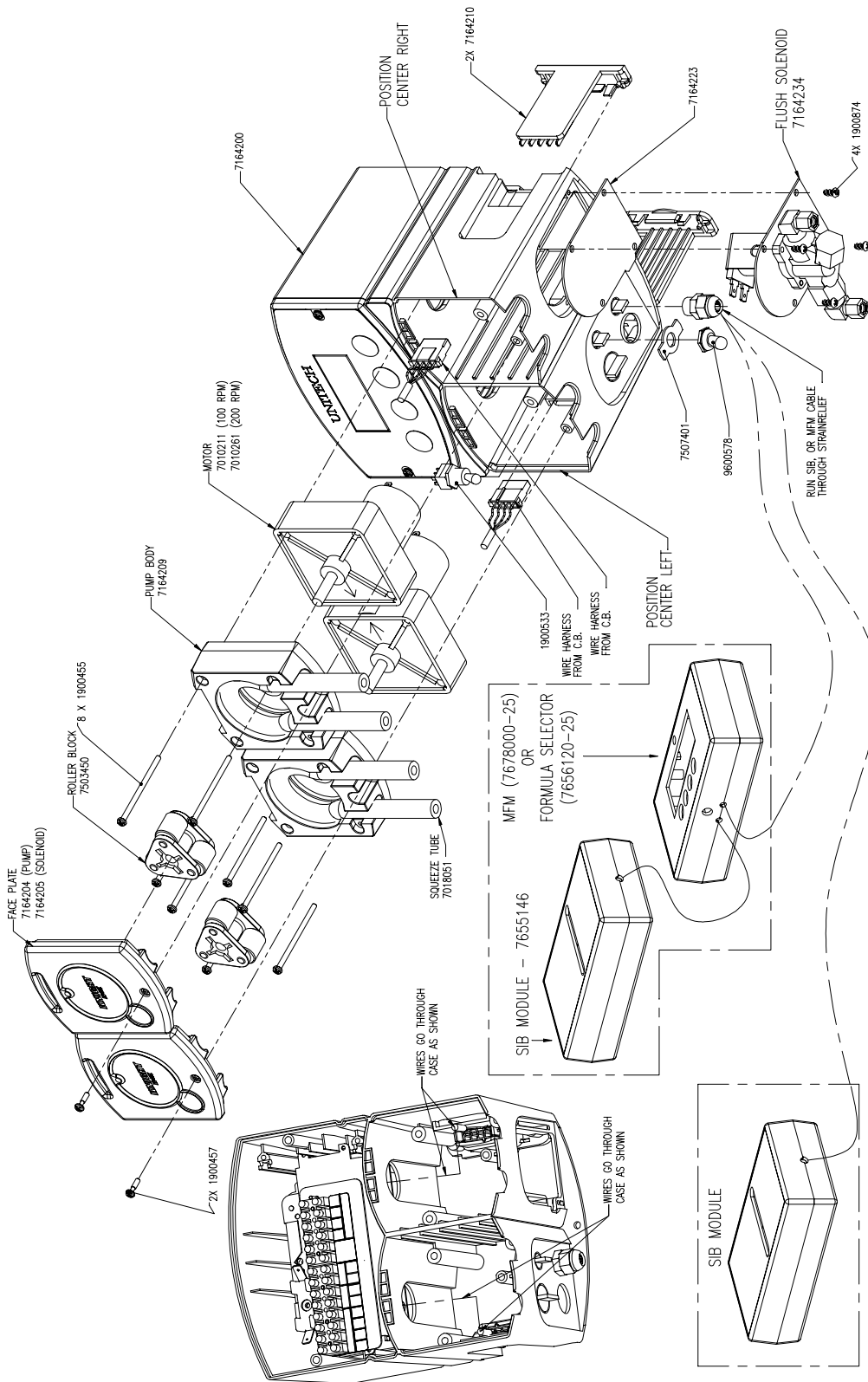

PARTS DIAGRAM — 800 SATELLITE

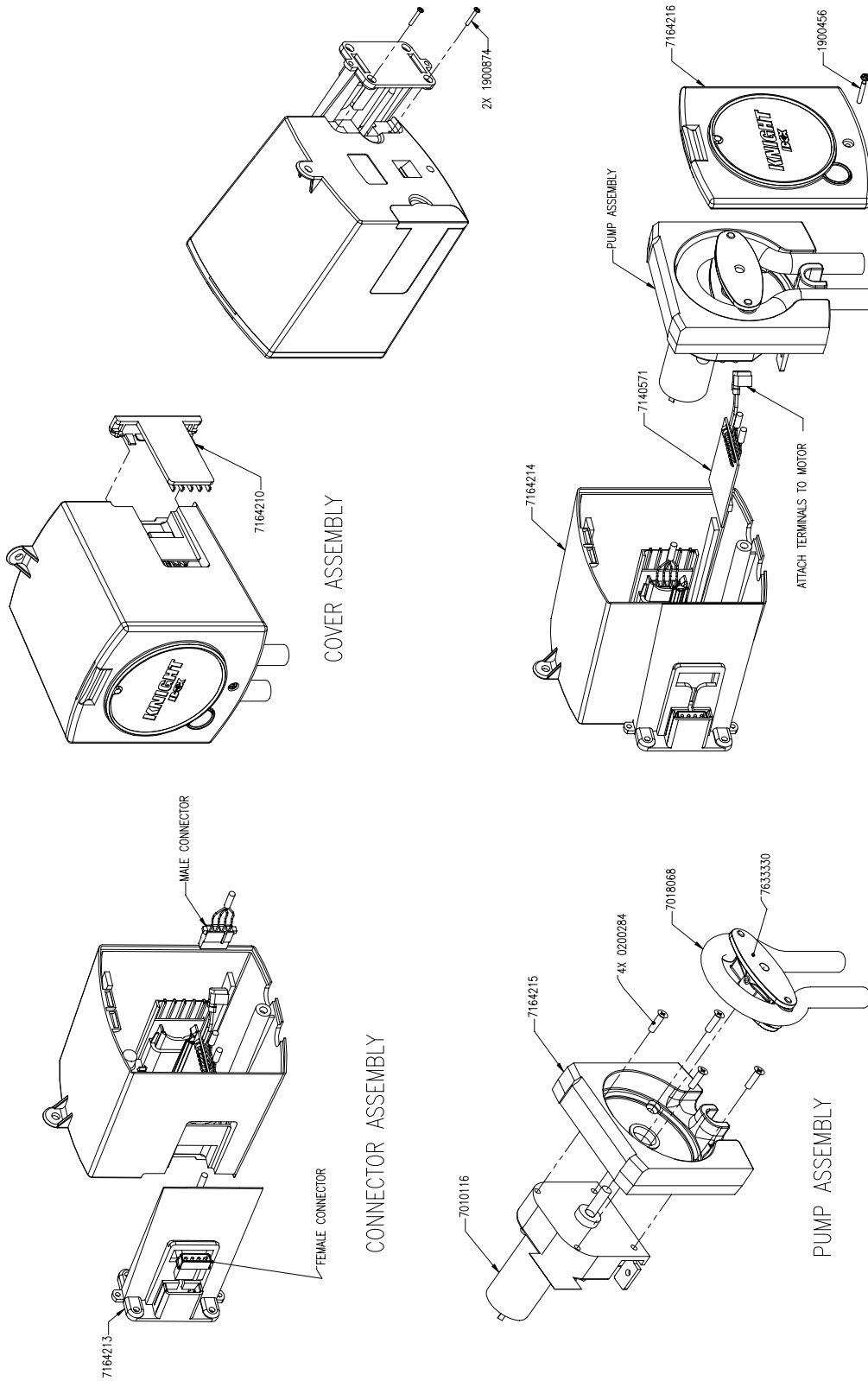

PUMP LAYOUT DIAGRAM

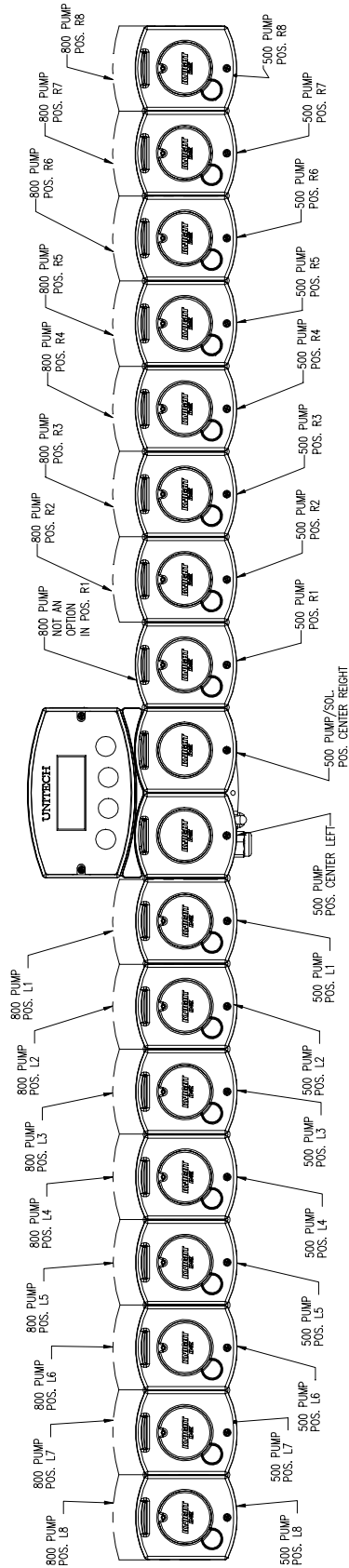

WIRING DIAGRAM

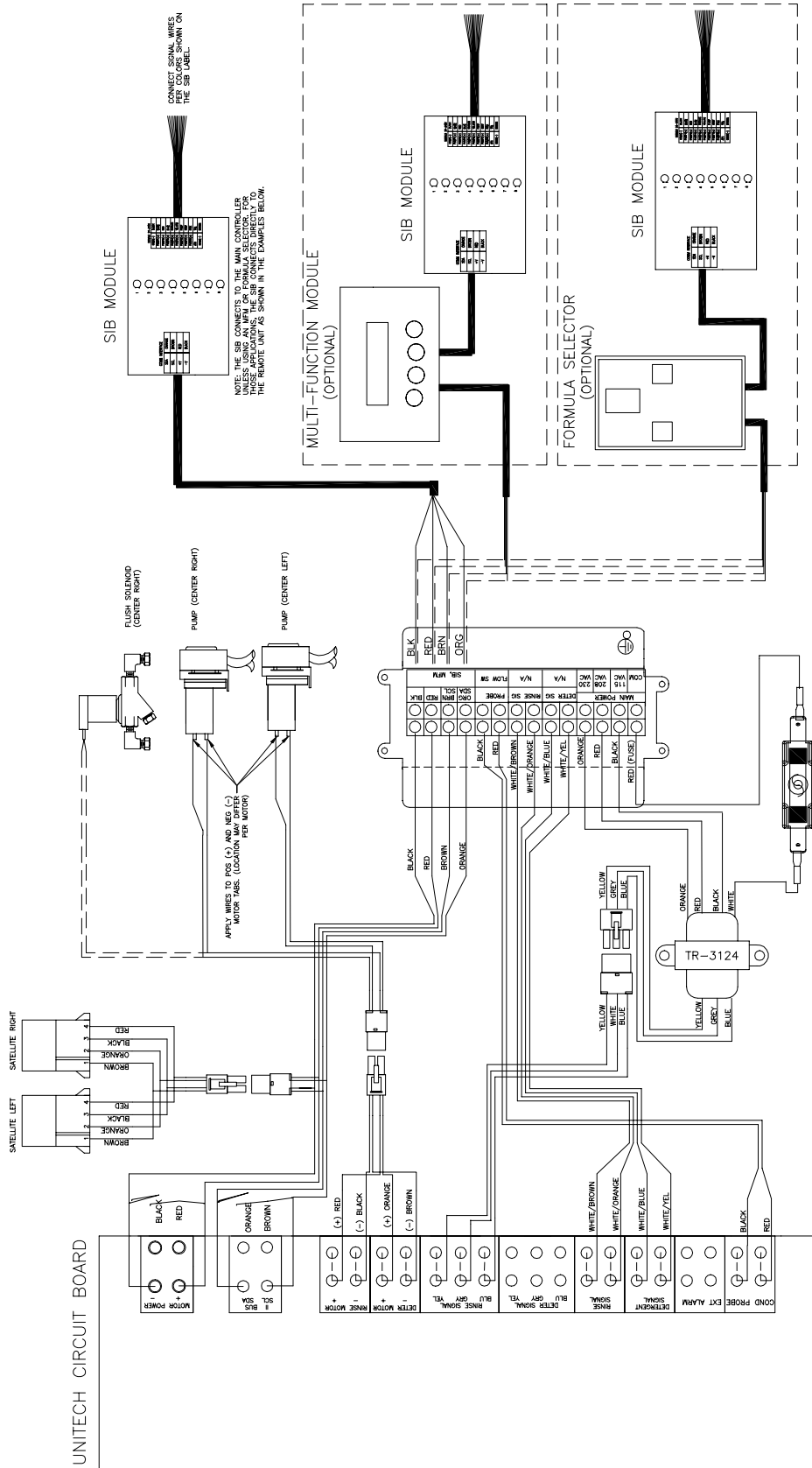



KNIGHT, INC.
A Unit of IDEX Corporation
20531 Crescent Bay Drive
Lake Forest, CA 92630-8825, U.S.A.
(949) 595-4800 • Fax (949) 595-4801
www.knightequip.com

EC – DECLARATION OF CONFORMITY

Equipment Description: Chemical Dispensing Equipment

Type/Model Number: UNITECH

The signing legal authorities state that the above mentioned equipment meets the requirements for emission, immunity and safety according to

GUIDELINE OF COUNSEL DIRECTIVE 89/336 EEC

(Adaptation of the regulations of the member countries regarding the electromagnetic compatibility (EMC))

AND

GUIDELINE OF COUNSEL DIRECTIVE 73/23 EEC AS AMENDED BY COUNCIL DIRECTIVES 92/59 EEC AND 93/68 EEC

(Adaptation of the regulations of the member countries regarding the low voltage directive (LVD))

and there it is allowed to carry the **CE – PROTECTION LABEL**.

The evaluation procedure of conformity was assured according to the following standards:

EN 55014
EN 61010

The EC –DECLARATION OF CONFORMITY is based on tests carried out at CSA International, Irvine CA and DNB Engineering, Riverside, CA.

Name: M.T. Whiting

Signature:

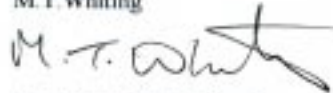

Position: Vice President, Engineering

Date: June 1st 2004



DISCLAIMER

Knight LLC does not accept responsibility for the mishandling, misuse, or non-performance of the described items when used for purposes other than those specified in the instructions. For hazardous materials information consult label, MSDS, or Knight LLC. Knight products are not for use in potentially explosive environments. Any use of our equipment in such an environment is at the risk of the user, Knight does not accept any liability in such circumstances.

WARRANTY

All Knight controls and pump systems are warranted against defects in material and workmanship for a period of ONE year. All electronic control boards have a TWO year warranty. Warranty applies only to the replacement or repair of such parts when returned to factory with a Knight Return Authorization (KRA) number, freight prepaid, and found to be defective upon factory authorized inspection. Bearings and pump seals or rubber and synthetic rubber parts such as "O" rings, diaphragms, squeeze tubing, and gaskets are considered expendable and are not covered under warranty. Warranty does not cover liability resulting from performance of this equipment nor the labor to replace this equipment. Product abuse or misuse voids warranty.

KNIGHT LLC, A Unit of IDEX Corporation

World Headquarters
20531 Crescent Bay Drive
Lake Forest, CA 92630
Tel: 949.595.4800
Fax: 949.595.4801
www.knightequip.com

USA Toll Free
Tel: 800.854.3764
Fax: 800.752.9518
Canada
Tel: 905.542.2333
Fax: 905.542.1536

Australia
Tel: 61.2.9725.2588
Fax: 61.2.9725.2025
UK
Tel: 44.1293.615.570
Fax: 44.1293.615.585

North Europe
Tel: 31.53.428.5800
Fax: 31.53.428.5809
South Europe
Tel: 34.93.487.1015
Fax: 34.93.215.2019

North Asia Pacific
Tel: 82.2.3481.6683
Fax: 82.2.3482.5742
Southeast Asia
Tel: 65.9170.0984
Fax: 65.6489.6723