

INTRODUCTION

The UniTech flush manifold offers an increased level of safety for operators as well as protection against corrosion to the washer and protection against chemical burns to the fabric. When the highly corrosive laundry chemicals are dispensed by the peristaltic pumps into the flush manifold, the unique flush mode of the control opens the built-in water solenoid to provide a diluted flush to the washer through a single injection line. Concentrated chemicals can now be dispensed with less chemical shock to the fabrics being washed. The built-in checkvalves prevent back-siphoning as well as cross contamination of the chemicals.

THEORY OF OPERATION

Liquid chemicals are dispensed into the flush manifold, and water is injected into the manifold to “push” the diluted chemistry to the washer. The delivery tube is then flushed clean in a post-flush operation and is ready for the next chemical. The flush mode of the UniTech dispenser flushes water “with” or “after” the chemical injections that are sent to the washer. Use of the optional “Flow Switch” will verify proper water flow, and shut the system down in the event of flush problems. Consult your UniTech programming manual for setting the flush mode.

PRE-INSTALLATION

Before mounting the manifold to the dispenser, a site survey should be performed to avoid installation problems and to identify any items that will be needed to complete the task. You may also wish to read through the rest of this manual to get familiar with the installation steps. Your site survey should include the following:

- Location of dispenser in relation to washer — dispenser can be located at the washer or remotely located with the chemical supplies. The dispenser should be no more than 100' from the washer.
- Determine proximity to water source — the water source should be as close to the dispenser as possible.
- Pressure and temperature of water source — system should operate at 20 to 40 PSI dynamic pressure. Warm or cool water temperatures are recommended for best results.
- Backflow prevention — local codes may require vacuum breakers or other safeguards for backflow prevention.
- Discharge tubing path from manifold to washer to determine length of delivery line required.
- Assessment of plumbing hardware required to connect an incoming water source — this will help identify what hardware is required, based on how you choose to plumb the system.



CAUTION: Wear protective clothing and eyewear when dispensing chemicals or other materials. Observe safety handling instructions (MSDS) of chemical mfrs.



CAUTION: To avoid severe or fatal shock, always disconnect main power when servicing the unit.



CAUTION: When installing any equipment, ensure that all national and local safety, electrical, and plumbing codes are met.

INSTALLATION

For reference purposes, you may wish to review the diagram on the following page before installation. An accessory kit is included with the parts needed to connect the chemical pumps to the manifold, and to connect the flush solenoid to the manifold. The kit does not include 1/2" delivery line to connect the output of the manifold to the washer.

► Optional Flow Switch

If the optional flow switch will be used, its recommended to attached it to the mounting bracket prior to installation of the manifold. The wiring barrier inside the UniTech main controller unit has terminals for connecting the flow switch. The wires should be connected during installation of the manifold (explained below).

► Flush Solenoid

If you are installing the manifold on a system without a flush solenoid, you will need to convert the unit by installing a flush solenoid in the right-hand pump location on the base unit.

- (1) Remove the pump and metal plate (on bottom) from the right-hand pump location on the base unit.
- (2) Install the flush solenoid through the bottom of the right-hand pump location.
- (3) The wiring harness inside the UniTech has connectors that will fit over the terminals on the flush solenoid. See the wiring diagram in the dispenser's instruction manual for further reference.

► Basic Installation Steps

- (1) Mount the manifold on the wall just below the UniTech dispenser using appropriate hardware. Center the manifold inline with the center of the main controller, so that the flush solenoid and all pumps can be easily connected to the manifold.
- (2) This step only applies if using the optional flow switch: Remove the left-side pump from the main controller (temporarily) to make the flow switch wiring easier. Remove a small knockout plug on the bottom of the controller and install the included strain relief fitting. Route the flow switch wires through the strain relief, then up into the top of the controller and attach to the wiring barrier (see the wiring diagram in the dispenser's instruction manual for reference). Put the left-side pump back in place and re-connect motor wires if necessary.
- (3) Cut the vinyl tubing (provided) to the required length for each pump. Use the provided barb fittings to connect the pump squeeze tubes to the vinyl tubes. Then connect the vinyl tubes to the checkvalves on the manifold. Cinch a tie wrap around each connection point to help prevent leakage.
- (4) Connect the output side of the flush solenoid to the input fitting on the manifold using the 1/4" poly tubing provided. If a flow switch is used connect the output side of the flush solenoid to the input fitting on the flow switch using the poly tubing, then connect a small loop of tube between the output of the flow switch and the input fitting on the manifold.
- (5) Connect the input side of the flush solenoid to a suitable water source. (20 to 40 PSI dynamic pressure, warm or cool water recommended).
- (6) Connect 1/2" ID tubing (delivery line) between the barbed output fitting on the manifold and the injection point on the washer. For best results, keep the distance between the manifold and the washer as short as possible. Avoid long vertical climbs that may require increased water pressure and/or lengthy flush time. Secured the connection with a hose clamp to prevent leakage.

MAINTENANCE

Routine inspection and maintenance of the flush manifold will ensure that it continues to provide trouble-free operation. Each time you visit the installation, check all hose and tubing connections for leaks or obstructions. In areas that have hard water, deposits can build up inside the flush solenoid, checkvalves, and manifold. Also check the flush line for obstructions or wear. Check that chemicals are flushing completely to the washer.

Checkvalves are like pump squeeze tubes in that they do wear over time. Checkvalves should be inspected on each service call to determine proper checking action and positive flow. The checkvalve has an internal PTFE ball and Viton seal — it is the user's responsibility to evaluate proper compatibility of laundry products to these checkvalves. Knight is not responsible for any damage resulting from product use or mis-use. The customer should determine a reasonable change out interval for checkvalves to assure proper performance and prevent chemical cross contamination or damage to lines.

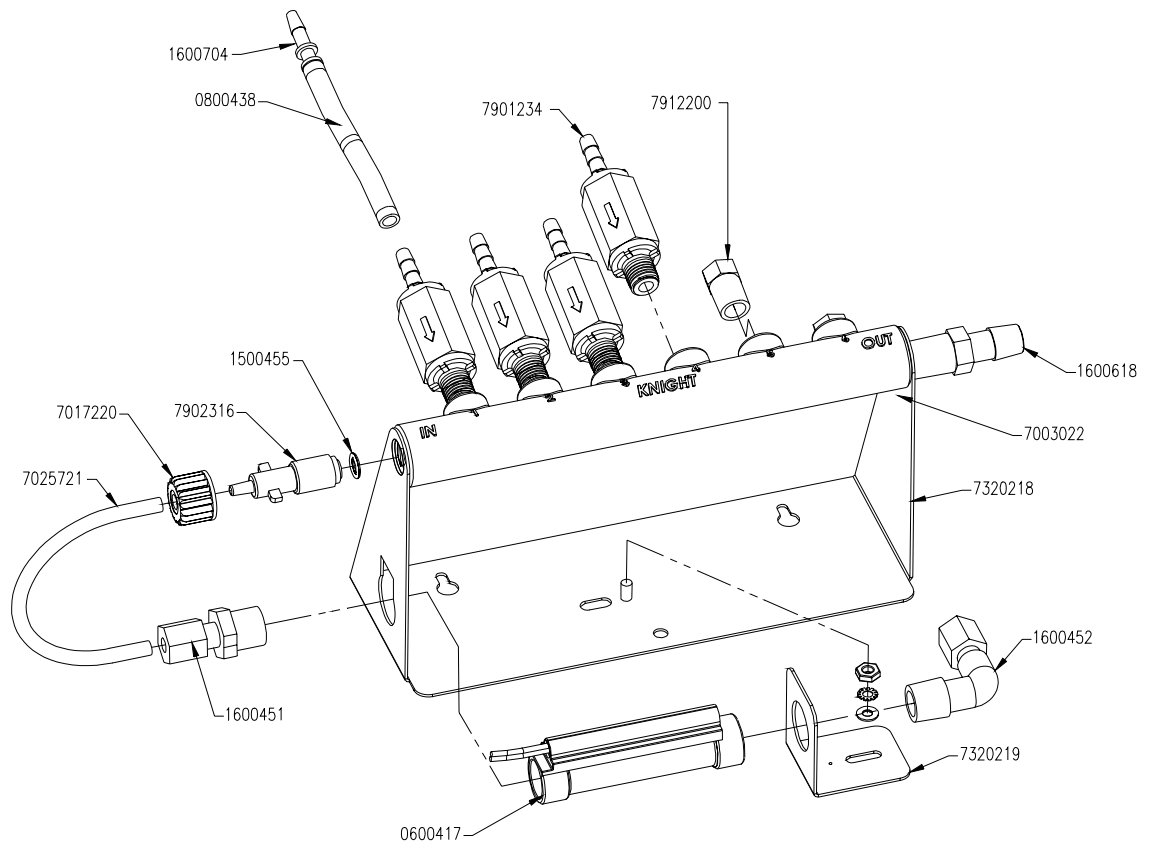
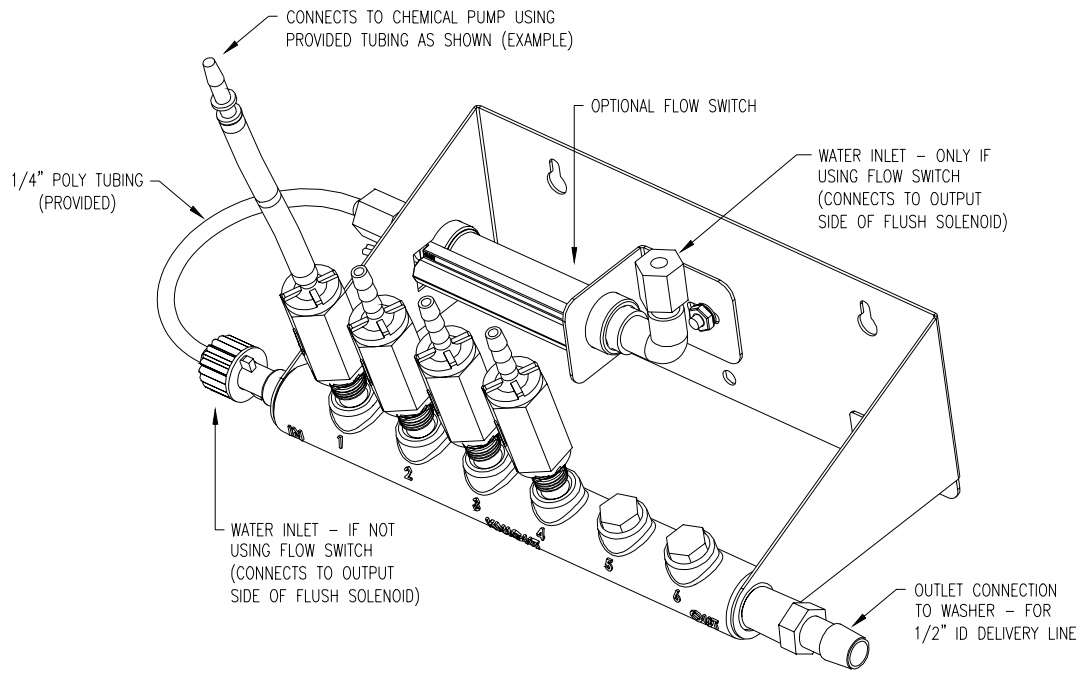

TROUBLESHOOTING

Flush water flowing constantly:

- Turn off power to dispenser — if flush stops, problem is related to the pump circuit board.
- If flush does not stop with power off, then problem is mechanical — may be debris or blockage inside the solenoid assembly, or may be a problem with the diaphragm inside the solenoid.

Flush water does not flow:

- Check to see if a “flush error” has happened — refer to the dispenser’s instruction manual for details.
- Check dispenser programming to ensure that proper flush time is programmed.
- Check solenoid coil to verify that it is receiving voltage from the dispenser.
- Check incoming water source for adequate pressure.
- Check for obstructions or debris inside the solenoid (around the diaphragm) and in the manifold output line.

Flush errors keep happening:

- Check flow switch (if used) for correct operation — this can be done with a continuity tester or multi-meter by verifying that the switch makes contact across its 2 wires when water flows through.
- Check the “Flush Flow Alarm” setting on the UniTech control to ensure its allowing enough time for minor fluctuations in the water line. This setting should be set to zero if the optional flow switch is not used.

Pumps do not dispense chemical into the manifold:

- Check the pump’s checkvalve fitting on the manifold — if it appears clogged, soak in warm water to clean, or replace checkvalve.
- Check for correct pump operation per troubleshooting tips in dispenser’s instruction manual.
- Check water pressure to manifold — pressure must be less than 40 PSI (dynamic).

DISCLAIMER

Knight LLC does not accept responsibility for the mishandling, misuse, or non-performance of the described items when used for purposes other than those specified in the instructions. For hazardous materials information consult label, MSDS, or Knight LLC. Knight products are not for use in potentially explosive environments. Any use of our equipment in such an environment is at the risk of the user, Knight does not accept any liability in such circumstances.

WARRANTY

All Knight controls and pump systems are warranted against defects in material and workmanship for a period of ONE year. All electronic control boards have a TWO year warranty. Warranty applies only to the replacement or repair of such parts when returned to factory with a Knight Return Authorization (KRA) number, freight prepaid, and found to be defective upon factory authorized inspection. Bearings and pump seals or rubber and synthetic rubber parts such as “O” rings, diaphragms, squeeze tubing, and gaskets are considered expendable and are not covered under warranty. Warranty does not cover liability resulting from performance of this equipment nor the labor to replace this equipment. Product abuse or misuse voids warranty.

FOOTNOTE

The information and specifications included in this publication were in effect at the time of approval for printing. Knight, LLC reserves the right, however, to discontinue or change specifications or design at any time without notice and without incurring any obligation whatsoever.

KNIGHT LLC, A Unit of IDEX Corporation (www.knightequip.com)

Knight Headquarters Tel: 949.595.4800 Fax: 949.595.4801	USA Toll Free Tel: 800.854.3764 Fax: 800.752.9518	Knight Canada Tel: 905.542.2333 Fax: 905.542.1536	Knight Europe Tel: 44.1293.615.570 Fax: 44.1293.615.585	Knight Australia Tel: 61.2.9725.2588 Fax: 61.2.9725.2025	Knight N. Asia Tel: 82.2.3481.6683 Fax: 82.2.3482.5742	Knight S. Asia Tel: 65.6763.6633 Fax: 65.6764.4020
--	--	--	--	---	---	---