

INTRODUCTION

The PMP Plus Series peristaltic and electric diaphragm metering pump systems are designed to dispense a variety of cleaning, sanitizing, lubrication and water treatment chemicals. Positive, accurate metering of liquids can be triggered manually or by a process control signal.

The PMP Plus Series offers a range of variable speed controlled flow rates with 30 PSI peristaltic or 100 PSI electric diaphragm pump and a standard multi-function pump controller with selectable feed modes including limit-timer, repeating cycle timer, relay/direct feed and push button activation. Variable speed control of the pump flow rate can be set manually or by a remote 4—20mA input from a process control. PMP Plus is built with Knight's field proven, long-life pumps. The moisture-sensitive motor and controller are enclosed in a corrosion-resistant, watertight, powder-coated case that stands up well for indoor applications.

KEY FEATURES / BENEFITS

- Auto-Start or Optional Manual Button Activation
- Watertight, Secure Locking Enclosure
- Long-Life Peristaltic or Electric Diaphragm Pumps (“EDP”)
- Water Resistant Case w/“D” Shaped Silicone Gasket
- Long Lasting Squeeze Tubes and Valves Seals
- Variable Speed Control
- 4—20mA speed control input to vary pump delivery volume with process
- “Batch Feed” mode (Timer)
- “Repeat Cycle” mode
- Programmable Pump Delay
- Wide Range of Flow Rates
- Microprocessor, Push Button Programming
- Pumps Pressure from 30 to 100 PSI
- Pressure Switch option
- Pump Lockout Option

APPLICATIONS

FOOD & BEVERAGE PROCESSING PLANTS: CIP Sanitizer Injection, COP Dosing, Bucket Fill, Conveyor Lube, Cart Washer, Water Treatment, Odor Control Misting

DAIRY: Pipeline Cleaning/Sanitizing, Teat Dip Chemical, Wash Pen Chemical Injection

INDUSTRIAL: General Cleaning, Machinery Lubrication, Cooling Towers, Boilers

TRANSPORTATION: Car Wash Stations



PMP-EDP Series



PMP-900 Series



Remote Activator

WARNING!

- Pump designed to operate with factory supplied fittings.**
- Use “Worm Gear” clamps only for all liquid end connections**
- Minimum suction tube I.D. must be 3/8” for 800, 770, 8110 Series Pumps**
- Minimum suction tube I.D. must be 1/2” for 900, 9100, 550 Series Pumps**
- There can be no other restrictions on suction tube.**
- Factory warranty is void if installation and operating procedures are not followed, see instruction manual.**
- Call Knight for technical support if needed, (800) 854-3764 or go to our website www.knightequip.com**

KNIGHT
A Unit of **IBEX** Corporation



CAUTION: Wear protective clothing and eyewear when dispensing chemicals or other materials. Observe safety handling instructions (MSDS) of chemical mfrs.



CAUTION: To avoid severe or fatal shock, always disconnect main power when servicing the unit.



CAUTION: When installing any equipment, ensure that all national and local safety, electrical, and plumbing codes are met.

RECOMMENDED OPERATING PARAMETERS

Pump Model	Duty Cycle	Maximum Pump Run Time	Maximum Lift (Suction)	Maximum Head Pressure
PMP-800 Models	50%	5 Minutes	10 Feet (3 Meters)	30 PSI (2 Bar)
PMP-900 Models	50%	5 Minutes	10 Feet (3 Meters)	30 PSI (2 Bar)
PMP-EDP Models	70%	60 Minutes	15 Feet (4.5 Meters)	100 PSI (6.9 Bar)

NOTE: The duty cycles and maximum pump run time specified above can be exceeded, however in doing so the life of the squeeze tube, roller block and motor may be reduced.

SPECIFICATIONS

- Enclosure: Powder coated stainless steel.
- Pump Drive: Variable DC.
- Squeeze Tube and Valve Seal Materials: Material available for most chemical applications.
- Control: Limiting timer, repeating cycle timer, or relay mode.
- Dimensions: PMP Plus-800: 9.3"H x 5.8"W x 5"D (23.6cm x 14.7cm x 12.7cm)
PMP Plus-900: 13.6"H x 8"W x 7.5"D (34.5cm x 20.3cm x 19.1cm)
PMP Plus EDP: 13.6"H x 8"W x 7.5"D (34.5cm x 20.3cm x 19.1cm)
- Pollution Degree II
- Installation category I
- Altitude 2000m
- Humidity 5 to 95%
- Electrical supply 115VAC/60HZ, 230VAC/60HZ, 230VAC/50HZ, 2A
- For Indoor Use Only
- Temperature 5°C to 40°C
- Mains supply voltage fluctuations are not to exceed 10% of the nominal supply voltage
- The unit shall not be positioned so that it is difficult to operate the power disconnecting means
- Protection is impaired if the product is used in a manner not specified by the manufacturer
- Replacement Fuse for 115V/230V model: 2Amp, 250V, 6.3x32mm, Fast-Acting

PROGRAMMING SETTINGS

Operating Mode	Signal Input	Pump "ON" Time	Pump "OFF" Time	Delay On Time	On First	Off First
KTM	14—240 VAC/VDC	0—12 min 42 sec		0—12 min 42 sec	Select	Select
CT	14—240 VAC/VDC	0—12 min 42 sec	0—255 min	0—12 min 42 sec	Select	Select
Relay	14—240 VAC/VDC	1 sec to continuous				
4—20 mA	External Input (PLC)					

THEORY OF OPERATION

The PMP Plus chemical metering systems come standard with a unique microcontroller that provides extreme versatility of use. The multi-function pump controller varies the speed of the pump to provide accurate, precise injections for almost any chemical batch feed application, repeat cycle injection, pumped misting applications and direct closed loop injection. The integral circuit board has dual dip switch program/mode selectors that provide the following operations:

KTM Mode (Timer) Dip Switch#5— This pump “Limit Timer” control is designed to control the run time of the pump with the press of a button or input of a signal from a powered switch or remote controller. The water proof control cabinet is normally mounted near the delivery point for the chemical, convenient for operators. Typical delivery points include Gerry cans, buckets, floor scrubbers, portable foamers or other receptacles. For applications where remote triggers such as a CIP or Conductivity control signal are used, the controller can be installed close to the signal source. The signal-input circuit accepts input voltages from 14-240 VAC. The MFSC board also has a “Relay Mode” feature that allows the pump to run from a 14 – 240V signal (for as long as the signal is present) or while the push button is held down. Using the relay mode with the push button is well suited for manual feed applications.

CT Mode (Repeat Cycle) Dip Switch#5 — This pump “Cycle Timer” triggers a continuous On-Off feed cycle anytime power is applied to the power input. For continuous chemical applications such as conveyor or track lubrication, the Repeat Cycle Timer Mode will feed from 0-12 minutes of ON time, with an OFF time from 0-255 minutes off.

INSTALLATION—PERISTALTIC MODELS

- (1) Check voltage of installation with a voltmeter and compare with voltage inputs of pump unit before mounting. Application of incorrect voltage will permanently damage unit and is not covered under warranty.
- (2) Mount unit on wall or shelf in a convenient location near both injection point and chemical supply. Do not mount unit in direct path of steam. This can short circuit and permanently damage your system.
- (3) Install power leads. Most systems include a power cord for easy connection. Variable speed systems have an internal transformer which steps down the incoming voltage. Rigid or flexible conduit should be used to ensure safety and continued operation without shorts. The green ground wire must be applied to ground. Failure to do so will void warranty.
- (4) Install braided tubing between the discharge (right) tube side of the peristaltic pump and the injection point. Use the provided stainless steel hose clamps and barb fittings to secure braided tubing to squeeze tube.
- (5) Install braided tubing between the suction (left) tube side and the barb fitting on the PVC pickup tube provided. Use the provided stainless steel hose clamps and barb fittings to secure braided tubing to squeeze tube.

INSTALLATION—ELECTRIC DIAPHRAGM MODELS

- (1) Check voltage of installation with a voltmeter and compare with voltage inputs of pump unit before mounting. Application of incorrect voltage will permanently damage unit and is not covered under warranty.
- (2) Mount unit on wall or shelf in a convenient location near both injection point and chemical supply. Do not mount unit in direct path of steam. This can short circuit and permanently damage your system.
- (3) Install power leads. Most systems include a power cord for easy connection. Rigid or flexible conduit should be used for all 115 and 230 VAC installations to ensure safety and continued operation without shorts. The green ground wire must be applied to ground. Failure to do so will void warranty.
- (4) Install vinyl hose between the discharge (right) tube side of the pump and the injection point. Use hose clamps to secure tubing to fittings. For all hose routing, avoid any sharp bends which may crimp tubing and restrict flow. As an alternative, use 90 elbow fittings, but only if absolutely necessary.
- (5) Install vinyl hose between the suction (left) tube side and the PVC product pickup tube provided.

PRIMING THE PUMP

- (1) Locate the dip-switch pack on the lower left corner of the circuit board; set switch #2 to RUN, set switch #4 to RELAY, and switch #7 to SIGNAL.
 - (2) Press and hold the Start button until the chemical line is fully primed, then release the button.
 - (3) When finished priming, set switch #4 to TIMER (unless you intend to use relay mode).
-

PROGRAMMING KTM (TIMER) MODE

Pump Run Time: (max run time is 12 minutes and 42 seconds)

- (1) Locate the dip-switch pack on the lower left portion of the circuit board — set switch #2 to Program, set switch #3 to RUN TIME and set switch #7 to Signal MODE.
- (2) Using a measuring cup or beaker, press Start switch and release when pump starts. Let the pump run until desired amount of chemical is dispensed then press Start switch again to stop. The run time is now programmed. Repeat step if new volume is required.
- (3) Set mode switch #2 to RUN MODE.

Delay Time: (max delay time is 12 minutes and 42 seconds)

- (1) Locate the dip-switch pack on the lower left portion of the circuit board — set switch #7 to SIGNAL, set switch #3 to DELAY TIME and set switch #2 to PROGRAM MODE.
- (2) Press Start switch and release when the LED begins flashing. When the desired delay time has passed, press the Start switch again. The delay time is now programmed. Repeat step if new delay time is required.
- (3) Set mode switch #2 to RUN MODE.

Lock-Out Time: (max lock-out time is 255 minutes) See Dip Switch located on right side of circuit board.

This feature defeats consecutive dispensing of product for a pre-determined interval. Select a combination of switches 1 – 8 to program total lock-out time.

Example: For 10 minute lock-out, set switches #2 and #4 to ON with all other switches OFF.

For maximum lock-out (255 min) set all switches ON.

For no lock-out, set all switches OFF.

OPERATION—KTM (TIMER) MODE

Manual activation: Press the Start button for 1 full second. The unit will begin counting down the delay time (if used) and will then run the pump for the amount of time programmed. Once the lock-out time expires (if used) the pump will be ready to restart.

Signal activation: When the signal input on the circuit board receives a 14-240VAC trigger signal for at least 5 seconds, the delay time (if used) will begin counting down. Then the pump will run for the amount of time programmed. Once the lock-out time expires (if used) the pump will be ready to restart.

RELAY MODE

- (1) Locate the dip-switch pack on the lower left corner of the circuit board; set switch #2 to RUN, set switch #4 to RELAY.
- (2) Set switch #1 to POT for the pump speed to be controlled by the on-board potentiometer. If the pump speed will be controlled by a 4—20 mA signal, then set switch #1 to 4—20 mA.
- (3) Set switch #7 to SIGNAL if you want the pump to activate for as long as an external trigger signal is present, or for as long as the manual button is depressed. Set switch #7 to POWER-UP if you want the pump to run for as long as main power is on (no signal required).

DISABLING THE START BUTTON

There is a jumper marked “JP1” on the circuit board that can be used to prevent manual activation in certain applications, or to allow manual activation by remote push-button only. This jumper only affects the on-board start button. A remote start button, or trigger signal, can always be used to activate the pump.

- When the jumper is ON, the on-board start button is functional.
- When the jumper OFF, the on-board start button is disabled.

OPERATING MODES

Dip Switch #1 (Pot—4-20 mA)

- Select Pot for potentiometer pump speed control (on board)
- Select 4-20 mA for installations where automatic process controlled flow rates are required

Dip Switch #2 (Program—Run Mode)

- Program mode explained in previous pages
- Run Mode is selected after programming has been completed

Dip Switch#6 (On First—Off First)

- In the On First position the system will execute the dispense time function for Timer or Repeat Cycle mode when power is first applied. If a Delay time is programmed the LED will flash until Delay time is elapsed before the pump starts.
- In the Off First position the system will execute the “off” time function for Repeat Cycle mode when power is first applied.

Dip Switch #7 (Signal—Power Up)

The signal input feature is particularly useful for CIP and other control interface applications. The signal input circuitry will accept any signal voltage in the range of 14 – 240V. Check the signal voltage with a meter before connecting to the circuit board.

In the Power Up position allows the pump to be powered by the main power source and run when main power is applied to the system.

In the Signal position the system requires an input signal from a process control or any voltage signal with an effective range of 14 –240 VAC

PROGRAMMING CT (REPEAT CYCLE) MODE

Locate dip switch #5 and select CT Mode

- Maximum ON time is 12 minutes and 42 seconds.
- Maximum OFF time is 255 minutes.

Setting “OFF” Time

Power should be off when changing this setting. The off time is set by selecting a combination of switches 1 – 8. All switches that are turned ON will be added up to determine the total off time. For example, if you wish to set a 20 minute off time, set switches #3 and #5 to ON with all other switches OFF.

- For maximum off time (255 min) set all switches ON.
- The off time resets and begins counting down again the next time the pump runs.

Setting “ON” Time

- (1) Ensure that power is on. Be aware that the pump *may* run briefly — this is normal as the pumps are tested at the factory during final QC inspection.
- (2) Locate the dip-switch pack on the circuit board — set switch #2 to PROGRAM.
- (3) Using a measuring cup or beaker, press Start switch and release when pump starts. Let the pump run until desired amount of chemical is dispensed then press Start switch again to stop. The on time is now programmed.
- (4) Set mode switch #2 to RUN MODE.

SPEED CONTROL

Pump Speed Control is accomplished by manually adjusting pump speed to a desired output speed/concentration using the circuit board mounted potentiometer or by a dedicated 4-20mA input signal from a PLC. Many CIP process controls and wash circuit programs are able to output variable signals that regulate the injection of sanitizers and other process chemicals to achieve targeted PPM concentrations that match fresh water flow rates or desired batch dose volumes. A simple two wire 4-20mA connection (+/-) from the PLC will run the pump at the rated speed (see charts on the following pages) and vary the flow rate as the control signal changes in amplitude.

NOTE: DIP switch #8 is used on 24V board configurations only, and is intended to maximize performance with 800 Series pumps. This switch allows you to select EPDM or Viton as the type of squeeze tube used with the pump.

CONNECTING A START SWITCH

A remote, or case mounted, start switch can be connected to the circuit board for manual activation of the pump. See the diagram below and the wiring diagrams on pages 13—18 that show where the start switch should be connected.

- Timer Activation: The start switch will activate the programmed feed time for KTM mode (see KTM MODE on page 5 for further details).
- Relay Mode: The start switch will run the pump for as long as the switch is depressed (see RELAY MODE on page 5 for further details)

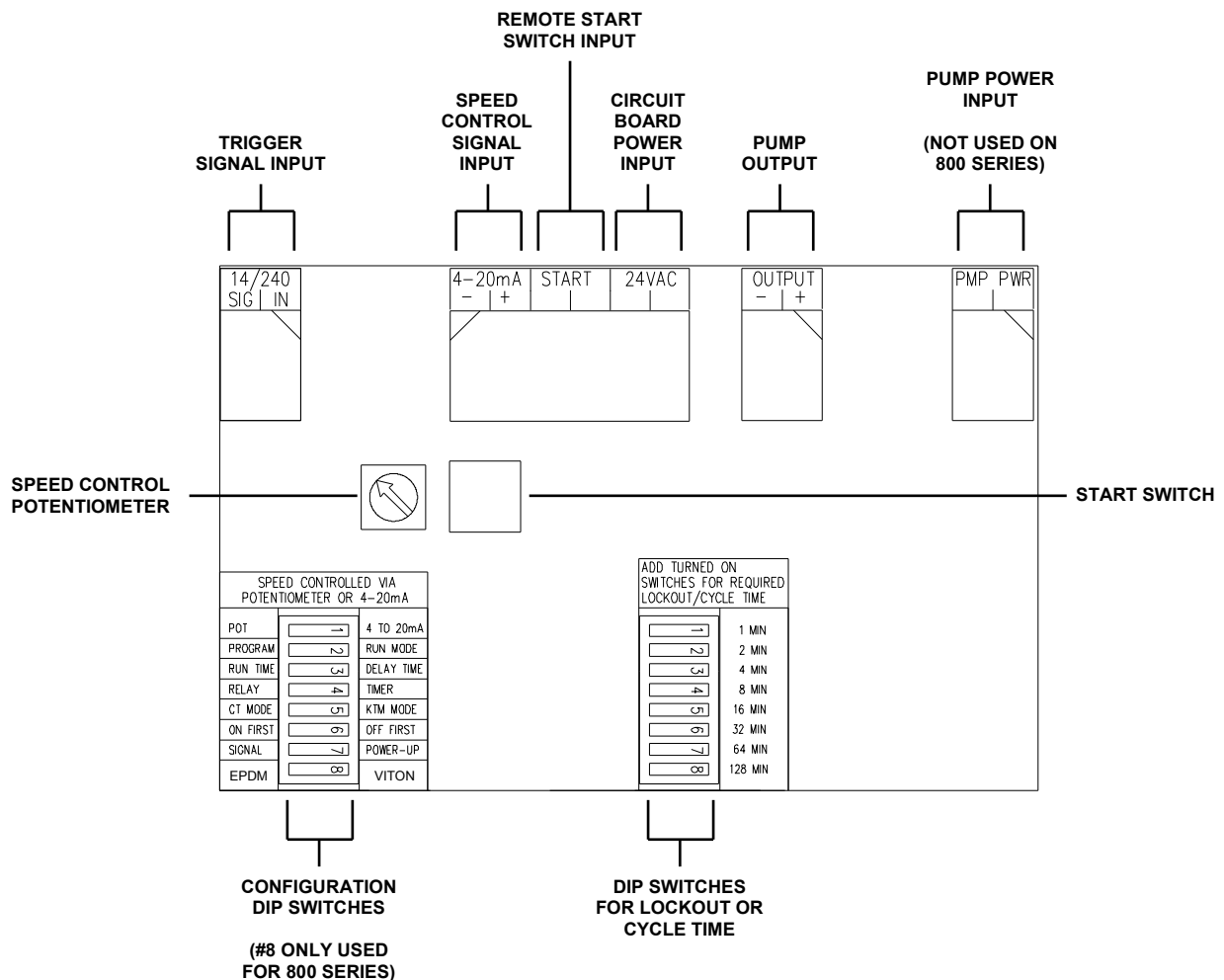

Current (ma)	Voltage (vdc)	Pump Speed Data .4 gpm Electric Diaphragm							
		115VAC				230VAC			
		Flow (gal/min)	Flow (oz/min)	Flow (L/min)	Flow (ml/min)	Flow (gal/min)	Flow (oz/min)	Flow (L/min)	Flow (ml/min)
3.00	0.72	0.000	0.000	0.000	0	0.000	0.000	0.000	0
3.60	0.864	0.000	0.000	0.000	0	0.000	0.000	0.000	0
4.20	1.008	0.040	5.072	0.150	150	0.048	6.087	0.180	180
4.80	1.152	0.096	12.342	0.365	365	0.116	14.878	0.440	440
5.40	1.296	0.144	18.429	0.545	545	0.177	22.655	0.670	670
6.00	1.44	0.199	25.530	0.755	755	0.248	31.785	0.940	940
6.60	1.584	0.248	31.785	0.940	940	0.301	38.548	1.140	1140
7.20	1.728	0.299	38.210	1.130	1130	0.361	46.156	1.365	1365
7.80	1.872	0.332	42.437	1.255	1255	0.427	54.610	1.615	1615
8.40	2.016	0.367	47.001	1.390	1390	0.489	62.556	1.850	1850
9.00	2.16	0.395	50.552	1.495	1495	0.510	65.261	1.930	1930
9.60	2.304	0.419	53.595	1.585	1585	0.535	68.473	2.025	2025
10.20	2.448	0.446	57.146	1.690	1690	0.567	72.531	2.145	2145
10.80	2.592	0.466	59.682	1.765	1765	0.590	75.574	2.235	2235
11.40	2.736	0.483	61.880	1.830	1830	0.612	78.279	2.315	2315
12.00	2.88	0.499	63.909	1.890	1890	0.630	80.646	2.385	2385
12.60	3.024	0.515	65.937	1.950	1950	0.650	83.182	2.460	2460
13.20	3.168	0.524	67.121	1.985	1985	0.663	84.873	2.510	2510
13.80	3.312	0.535	68.473	2.025	2025	0.680	87.071	2.575	2575
14.40	3.456	0.544	69.657	2.060	2060	0.692	88.593	2.620	2620
15.00	3.6	0.556	71.179	2.105	2105	0.703	89.945	2.660	2660
15.60	3.744	0.567	72.531	2.145	2145	0.712	91.129	2.695	2695
16.20	3.888	0.575	73.545	2.175	2175	0.716	91.636	2.710	2710
16.80	4.032	0.581	74.391	2.200	2200	0.724	92.650	2.740	2740
17.40	4.176	0.590	75.574	2.235	2235	0.733	93.834	2.775	2775
18.00	4.32	0.594	76.082	2.250	2250	0.738	94.510	2.795	2795
18.60	4.464	0.602	77.096	2.280	2280	0.741	94.848	2.805	2805
19.20	4.608	0.606	77.603	2.295	2295	0.745	95.356	2.820	2820
19.80	4.752	0.613	78.449	2.320	2320	0.793	101.442	3.000	3000
20.40	4.896	0.617	78.956	2.335	2335	0.794	101.611	3.005	3005

Current (ma)	Voltage (vdc)	Pump Speed Data 1.5 gpm Electric Diaphragm							
		115VAC				230VAC			
		Flow (gal/min)	Flow (oz/min)	Flow (L/min)	Flow (ml/min)	Flow (gal/min)	Flow (oz/min)	Flow (L/min)	Flow (ml/min)
3.00	0.72	0.000	0.000	0.000	0	0.000	0.000	0.000	0
3.60	0.864	0.000	0.000	0.000	0	0.000	0.000	0.000	0
4.20	1.008	0.026	3.381	0.100	100	0.055	7.101	0.210	210
4.80	1.152	0.133	17.076	0.505	505	0.161	20.627	0.610	610
5.40	1.296	0.221	28.235	0.835	835	0.246	31.447	0.930	930
6.00	1.44	0.339	43.451	1.285	1285	0.384	49.199	1.455	1455
6.60	1.584	0.428	54.779	1.620	1620	0.476	60.865	1.800	1800
7.20	1.728	0.516	66.106	1.955	1955	0.568	72.700	2.150	2150
7.80	1.872	0.584	74.729	2.210	2210	0.635	81.323	2.405	2405
8.40	2.016	0.650	83.182	2.460	2460	0.705	90.283	2.670	2670
9.00	2.16	0.715	91.467	2.705	2705	0.763	97.723	2.890	2890
9.60	2.304	0.758	97.046	2.870	2870	0.810	103.640	3.065	3065
10.20	2.448	0.806	103.133	3.050	3050	0.861	110.234	3.260	3260
10.80	2.592	0.841	107.698	3.185	3185	0.902	115.475	3.415	3415
11.40	2.736	0.880	112.601	3.330	3330	0.939	120.209	3.555	3555
12.00	2.88	0.913	116.827	3.455	3455	0.975	124.774	3.690	3690
12.60	3.024	0.943	120.716	3.570	3570	1.009	129.170	3.820	3820
13.20	3.168	0.968	123.928	3.665	3665	1.036	132.551	3.920	3920
13.80	3.312	0.992	126.972	3.755	3755	1.065	136.271	4.030	4030
14.40	3.456	1.001	128.155	3.790	3790	1.082	138.468	4.095	4095
15.00	3.6	1.033	132.213	3.910	3910	1.104	141.343	4.180	4180
15.60	3.744	1.066	136.440	4.035	4035	1.125	144.048	4.260	4260
16.20	3.888	1.071	137.116	4.055	4055	1.150	147.260	4.355	4355
16.80	4.032	1.090	139.483	4.125	4125	1.164	148.951	4.405	4405
17.40	4.176	1.104	141.343	4.180	4180	1.181	151.149	4.470	4470
18.00	4.32	1.120	143.371	4.240	4240	1.198	153.347	4.535	4535
18.60	4.464	1.127	144.217	4.265	4265	1.210	154.868	4.580	4580
19.20	4.608	1.147	146.753	4.340	4340	1.224	156.728	4.635	4635
19.80	4.752	1.157	148.105	4.380	4380	1.232	157.742	4.665	4665
20.40	4.896	1.172	149.965	4.435	4435	1.259	161.124	4.765	4765

Current (ma)	Voltage (vdc)	Pump Speed Data 3.2 gpm Electric Diaphragm							
		115VAC				230VAC			
		Flow (gal/min)	Flow (oz/min)	Flow (L/min)	Flow (ml/min)	Flow (gal/min)	Flow (oz/min)	Flow (L/min)	Flow (ml/min)
3.00	0.72	0.000	0.000	0.000	0	0.000	0.000	0.000	0
3.60	0.864	0.000	0.000	0.000	0	0.000	0.000	0.000	0
4.20	1.008	0.099	12.680	0.375	375	0.147	18.767	0.555	555
4.80	1.152	0.345	44.127	1.305	1305	0.371	47.509	1.405	1405
5.40	1.296	0.543	69.488	2.055	2055	0.561	71.855	2.125	2125
6.00	1.44	0.884	113.108	3.345	3345	0.902	115.475	3.415	3415
6.60	1.584	1.136	145.400	4.300	4300	1.131	144.724	4.280	4280
7.20	1.728	1.346	172.282	5.095	5095	1.335	170.930	5.055	5055
7.80	1.872	1.506	192.740	5.700	5700	1.510	193.247	5.715	5715
8.40	2.016	1.647	210.830	6.235	6235	1.672	214.043	6.330	6330
9.00	2.16	1.787	228.752	6.765	6765	1.818	232.640	6.880	6880
9.60	2.304	1.889	241.770	7.150	7150	1.944	248.871	7.360	7360
10.20	2.448	1.997	255.634	7.560	7560	2.074	265.440	7.850	7850
10.80	2.592	2.082	266.454	7.880	7880	2.170	277.782	8.215	8215
11.40	2.736	2.158	276.261	8.170	8170	2.243	287.081	8.490	8490
12.00	2.88	2.236	286.236	8.465	8465	2.345	300.099	8.875	8875
12.60	3.024	2.301	294.520	8.710	8710	2.425	310.413	9.180	9180
13.20	3.168	2.347	300.438	8.885	8885	2.485	318.021	9.405	9405
13.80	3.312	2.412	308.722	9.130	9130	2.562	327.996	9.700	9700
14.40	3.456	2.448	313.287	9.265	9265	2.609	333.913	9.875	9875
15.00	3.6	2.494	319.204	9.440	9440	2.671	341.860	10.110	10110
15.60	3.744	2.540	325.122	9.615	9615	2.729	349.299	10.330	10330
16.20	3.888	2.586	331.039	9.790	9790	2.787	356.738	10.550	10550
16.80	4.032	2.615	334.759	9.900	9900	2.829	362.148	10.710	10710
17.40	4.176	2.658	340.169	10.060	10060	2.872	367.558	10.870	10870
18.00	4.32	2.692	344.565	10.190	10190	2.919	373.645	11.050	11050
18.60	4.464	2.724	348.623	10.310	10310	2.956	378.379	11.190	11190
19.20	4.608	2.753	352.342	10.420	10420	2.994	383.282	11.335	11335
19.80	4.752	2.782	356.062	10.530	10530	3.027	387.509	11.460	11460
20.40	4.896	2.813	360.119	10.650	10650	3.068	392.750	11.615	11615

Current (ma)	Voltage (vdc)	Pump Speed Data 900 Series Peristaltic			
		Flow (gal/min)	Flow (oz/min)	Flow (L/min)	Flow (ml/min)
3.00	0.72	0.000	0.000	0.000	0.00
3.60	0.864	0.000	0.000	0.000	0.00
4.20	1.008	0.016	2.029	0.060	60.00
4.80	1.152	0.053	6.763	0.200	200.00
5.40	1.296	0.100	12.849	0.380	380.00
6.00	1.44	0.148	18.936	0.560	560.00
6.60	1.584	0.195	25.022	0.740	740.00
7.20	1.728	0.240	30.771	0.910	910.00
7.80	1.872	0.272	34.828	1.030	1030.00
8.40	2.016	0.312	39.901	1.180	1180.00
9.00	2.16	0.341	43.620	1.290	1290.00
9.60	2.304	0.370	47.340	1.400	1400.00
10.20	2.448	0.400	51.228	1.515	1515.00
10.80	2.592	0.428	54.779	1.620	1620.00
11.40	2.736	0.450	57.653	1.705	1705.00
12.00	2.88	0.465	59.513	1.760	1760.00
12.60	3.024	0.497	63.570	1.880	1880.00
13.20	3.168	0.509	65.092	1.925	1925.00
13.80	3.312	0.532	68.135	2.015	2015.00
14.40	3.456	0.539	68.981	2.040	2040.00
15.00	3.6	0.560	71.686	2.120	2120.00
15.60	3.744	0.560	71.686	2.120	2120.00
16.20	3.888	0.569	72.869	2.155	2155.00
16.80	4.032	0.582	74.560	2.205	2205.00
17.40	4.176	0.588	75.236	2.225	2225.00
18.00	4.32	0.592	75.743	2.240	2240.00
18.60	4.464	0.600	76.758	2.270	2270.00
19.20	4.608	0.609	77.941	2.305	2305.00
19.80	4.752	0.613	78.449	2.320	2320.00
20.40	4.896	0.625	79.970	2.365	2365.00

Current (ma)	Voltage (vdc)	Pump Speed Data 800 Series Peristaltic							
		Viton				EPDM			
		Flow (gal/ min)	Flow (oz/ min)	Flow (L/ min)	Flow (ml/ min)	Flow (gal/ min)	Flow (oz/ min)	Flow (L/ min)	Flow (ml/ min)
3.00	0.72	0.000	0.000	0.000	0.00	0.000	0.000	0.000	0.00
3.60	0.864	0.000	0.000	0.000	0.00	0.000	0.000	0.000	0.00
4.20	1.008	0.043	5.498	0.163	162.60	0.071	9.143	0.270	270.40
4.80	1.152	0.056	7.185	0.213	212.50	0.091	11.684	0.346	345.55
5.40	1.296	0.075	9.571	0.283	283.05	0.111	14.212	0.420	420.30
6.00	1.44	0.091	11.605	0.343	343.20	0.128	16.396	0.485	484.90
6.60	1.584	0.091	11.654	0.345	344.65	0.136	17.404	0.515	514.70
7.20	1.728	0.111	14.146	0.418	418.35	0.149	19.083	0.564	564.35
7.80	1.872	0.125	16.040	0.474	474.35	0.159	20.392	0.603	603.05
8.40	2.016	0.136	17.465	0.517	516.50	0.173	22.163	0.655	655.45
9.00	2.16	0.158	20.280	0.600	599.75	0.179	22.904	0.677	677.35
9.60	2.304	0.175	22.354	0.661	661.10	0.198	25.296	0.748	748.10
10.20	2.448	0.184	23.540	0.696	696.15	0.202	25.871	0.765	765.10
10.80	2.592	0.196	25.046	0.741	740.70	0.207	26.549	0.785	785.15
11.40	2.736	0.212	27.115	0.802	801.90	0.222	28.458	0.842	841.60
12.00	2.88	0.222	28.372	0.839	839.05	0.226	28.955	0.856	856.30
12.60	3.024	0.235	30.073	0.889	889.35	0.231	29.537	0.874	873.50
13.20	3.168	0.238	30.515	0.902	902.45	0.233	29.832	0.882	882.25
13.80	3.312	0.244	31.200	0.923	922.70	0.236	30.248	0.895	894.55
14.40	3.456	0.255	32.582	0.964	963.55	0.242	30.964	0.916	915.70
15.00	3.6	0.256	32.724	0.968	967.75	0.248	31.783	0.940	939.95
15.60	3.744	0.262	33.554	0.992	992.30	0.254	32.482	0.961	960.60
16.20	3.888	0.266	34.054	1.007	1007.10	0.259	33.166	0.981	980.85
16.80	4.032	0.270	34.597	1.023	1023.15	0.262	33.544	0.992	992.00
17.40	4.176	0.274	35.121	1.039	1038.65	0.267	34.189	1.011	1011.10
18.00	4.32	0.279	35.736	1.057	1056.85	0.269	34.387	1.017	1016.95
18.60	4.464	0.280	35.904	1.062	1061.80	0.275	35.153	1.040	1039.60
19.20	4.608	0.284	36.374	1.076	1075.70	0.277	35.459	1.049	1048.65
19.80	4.752	0.287	36.739	1.087	1086.50	0.280	35.851	1.060	1060.25
20.40	4.896	0.288	36.889	1.091	1090.95	0.285	36.470	1.079	1078.55

WIRING DIAGRAM—800 PERISTALTIC (115 VAC)

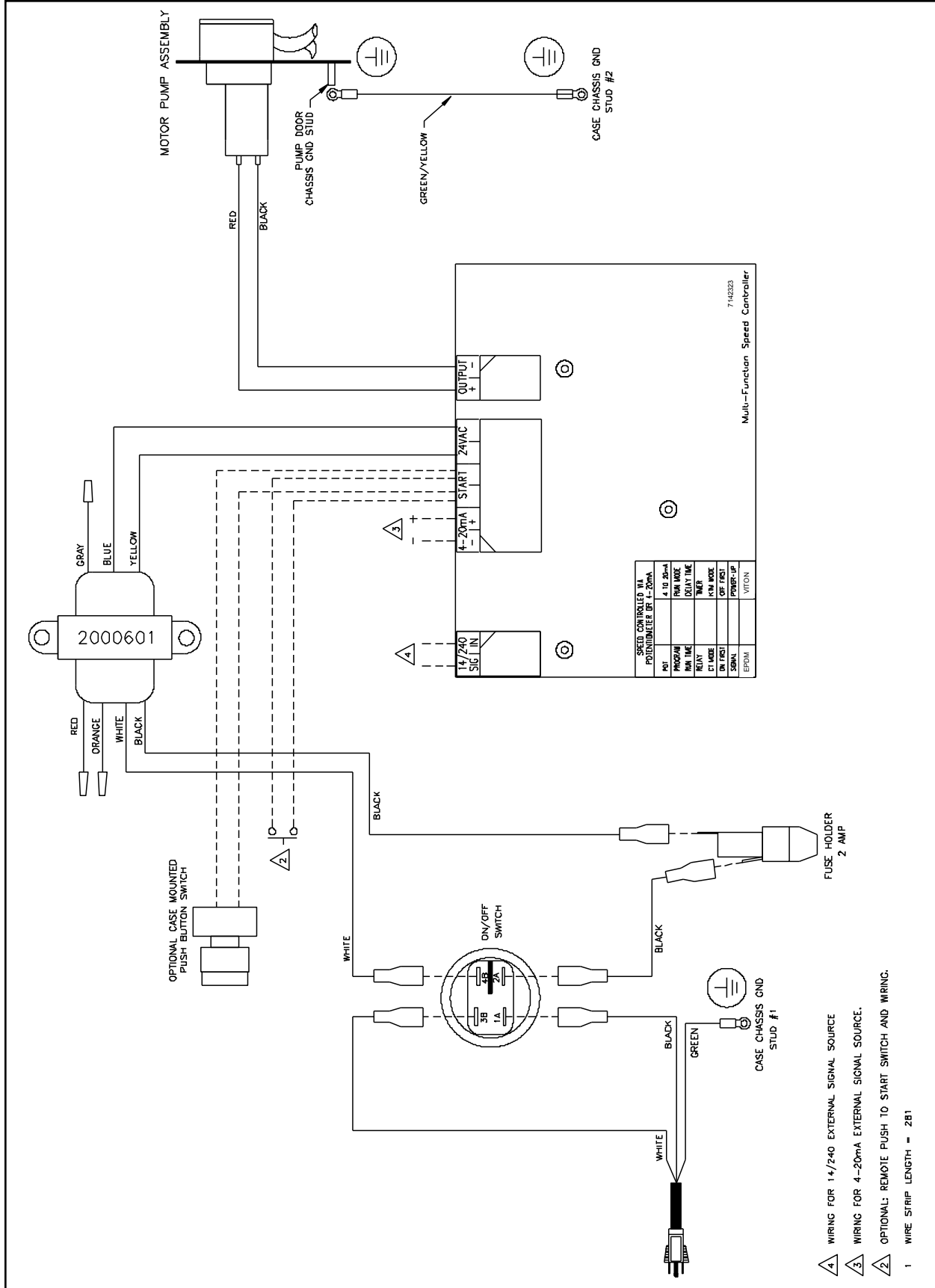

- ▲ 1 WIRING FOR 14/240 EXTERNAL SIGNAL SOURCE
- ▲ 2 WIRING FOR 4-20mA EXTERNAL SIGNAL SOURCE.
- ▲ 3 OPTIONAL: REMOTE PUSH TO START SWITCH AND WIRING.
- 1 WIRE STRIP LENGTH = 281

WIRING DIAGRAM—900 PERISTALTIC (115 VAC)

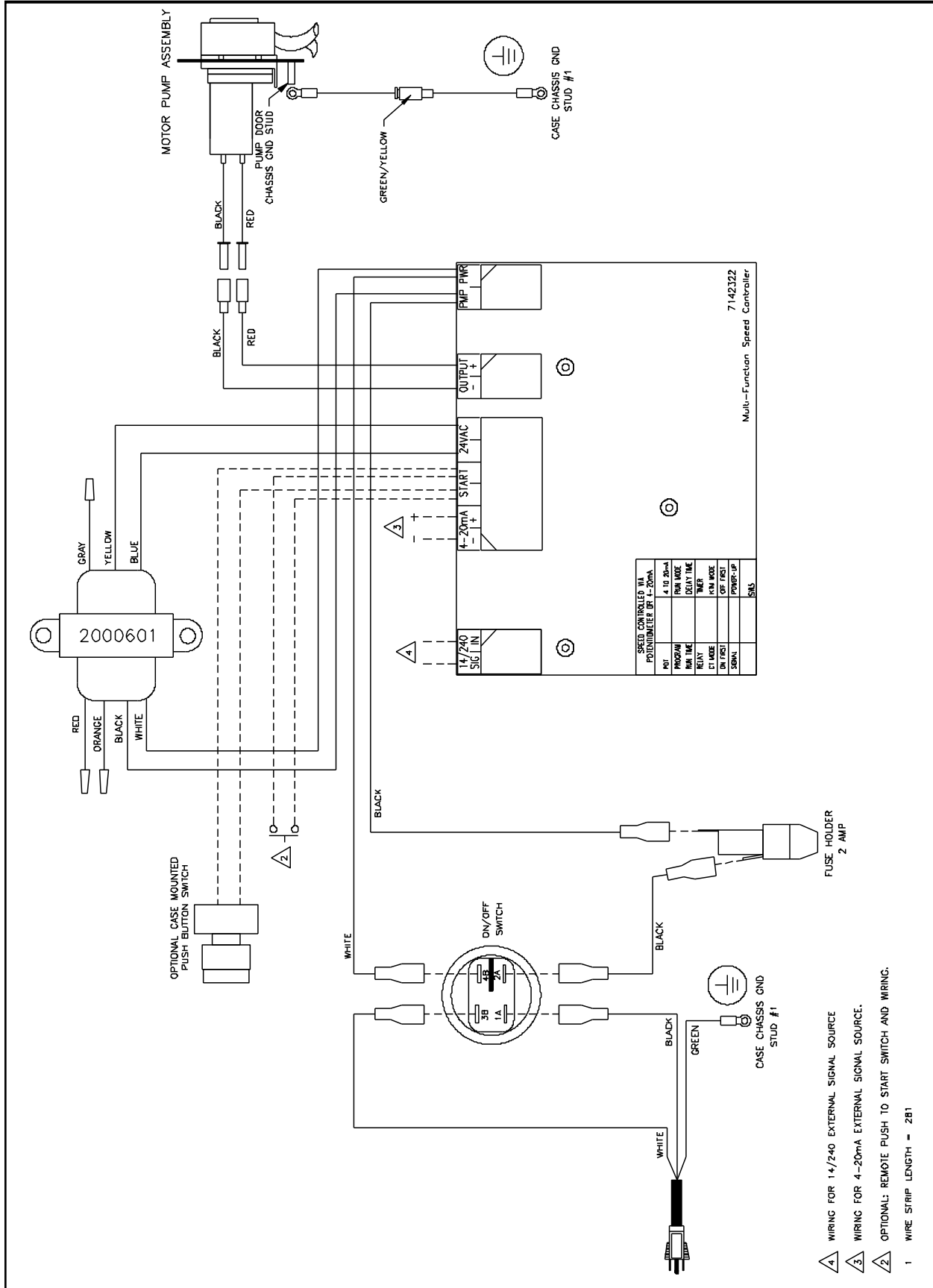

- 4 WIRING FOR 14/240 EXTERNAL SIGNAL SOURCE
- 3 WIRING FOR 4-20mA EXTERNAL SIGNAL SOURCE.
- 2 OPTIONAL: REMOTE PUSH TO START SWITCH AND WIRING.
- 1 WIRE STRIP LENGTH = 281

WIRING DIAGRAM—900 PERISTALTIC (230 VAC)

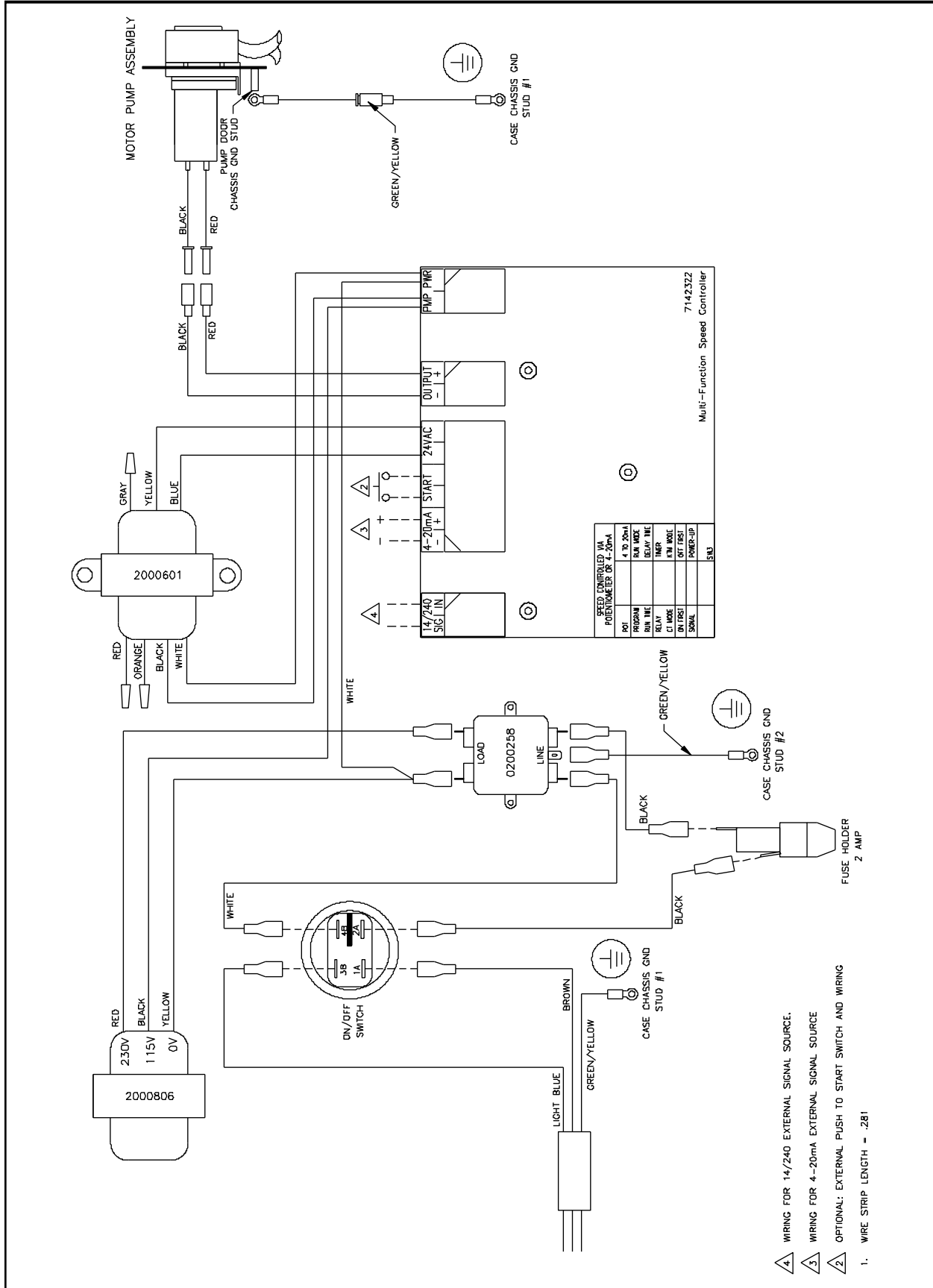

- 4 WIRING FOR 14/Z40 EXTERNAL SIGNAL SOURCE.
- 3 WIRING FOR 4-20mA EXTERNAL SIGNAL SOURCE
- 2 OPTIONAL: EXTERNAL PUSH TO START SWITCH AND WIRING

WIRING DIAGRAM—ELECTRIC DIAPHRAGM (115 VAC)

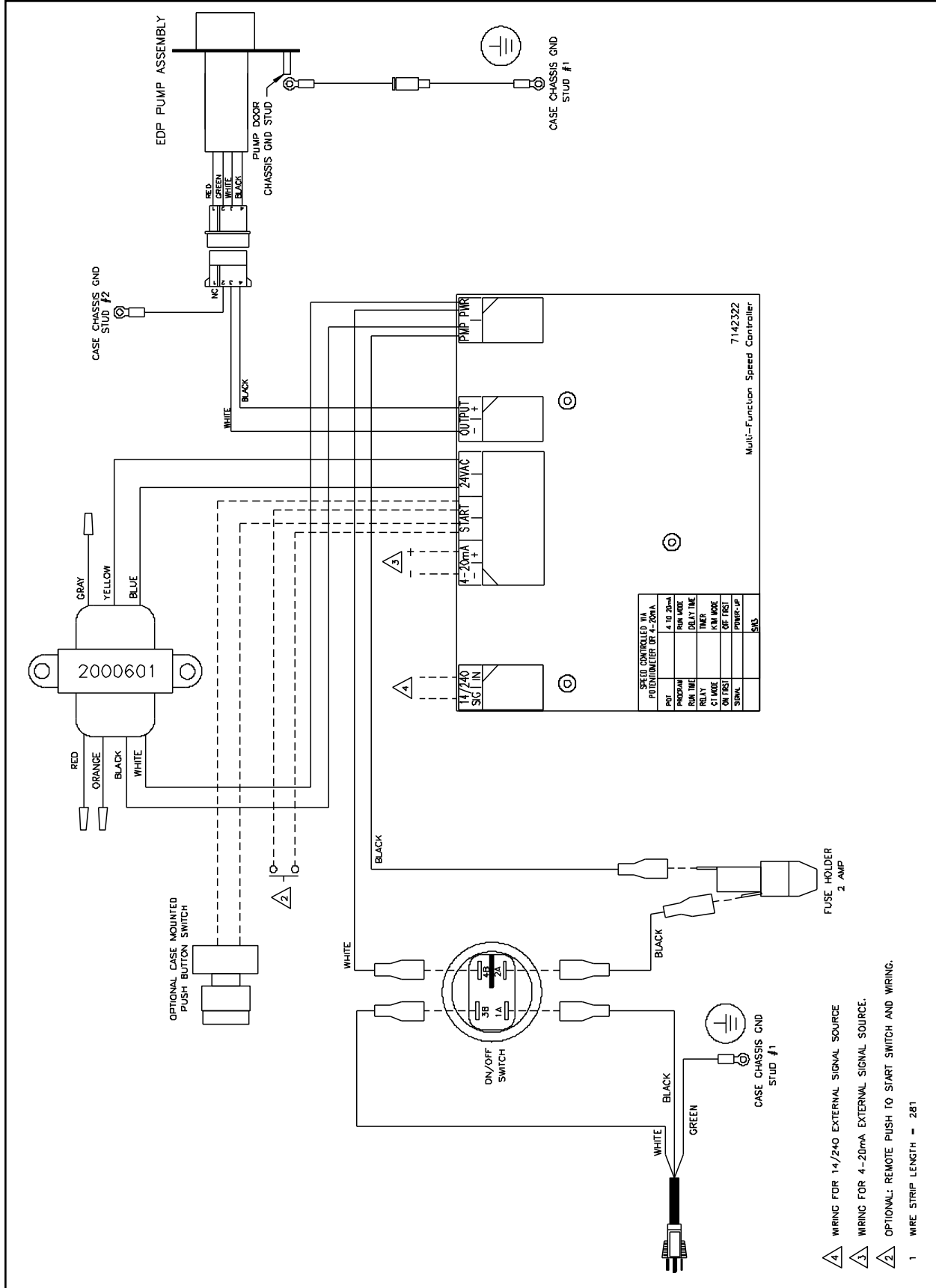

- 4 WIRING FOR 14/240 EXTERNAL SIGNAL SOURCE
- 3 WIRING FOR 4-20mA EXTERNAL SIGNAL SOURCE.
- 2 OPTIONAL: REMOTE PUSH TO START SWITCH AND WIRING.
- 1 WIRE STRIP LENGTH - 281

WIRING DIAGRAM—ELECTRIC DIAPHRAGM (230 VAC)

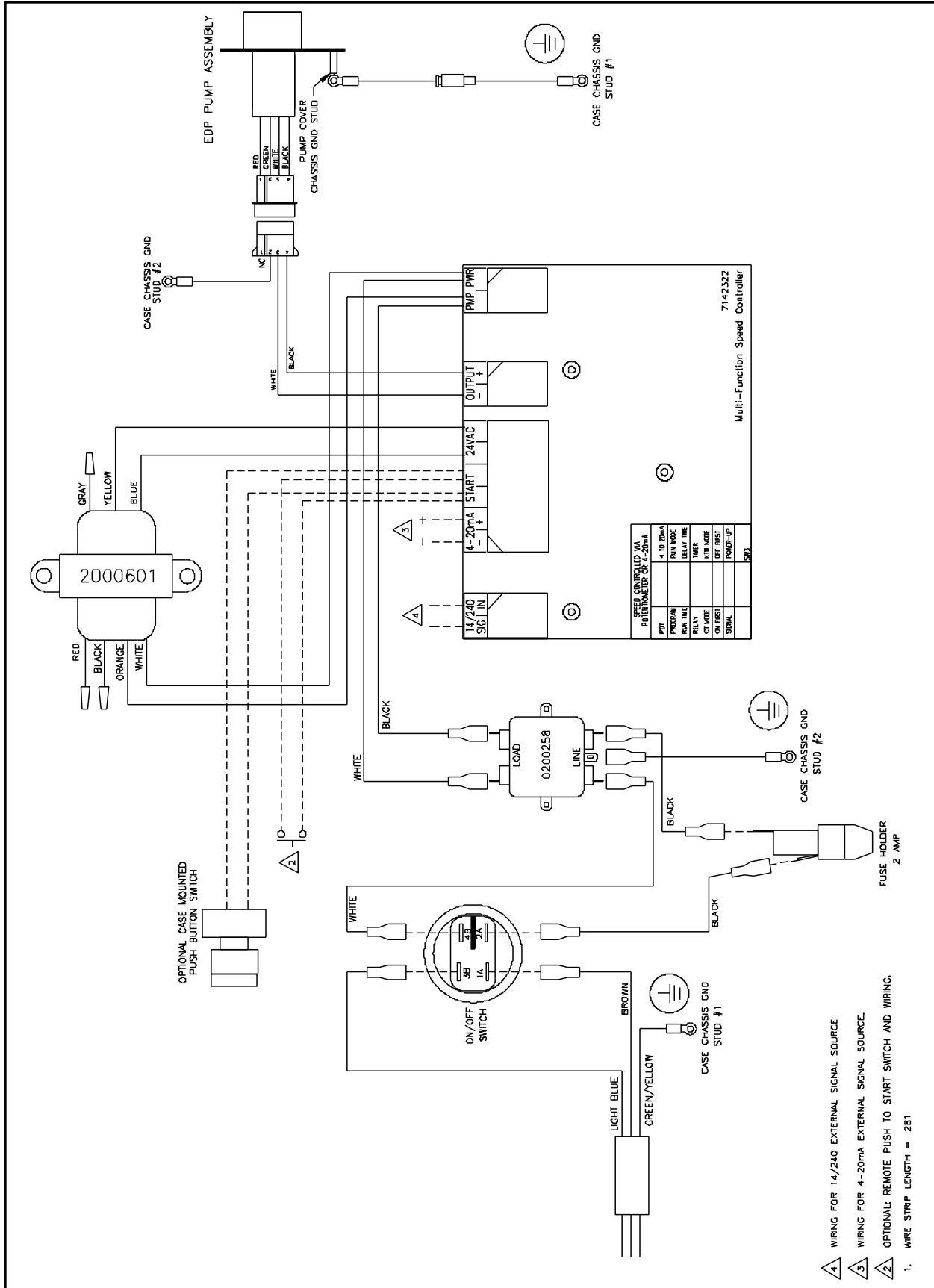

- 4 WIRING FOR 14/240 EXTERNAL SIGNAL SOURCE
- 3 WIRING FOR 4-20MA EXTERNAL SIGNAL SOURCE.
- 2 OPTIONAL: REMOTE PUSH TO START SWITCH AND WIRING.
- 1. WIRE STRIP LENGTH = 281

SPARE PARTS—PERISTALTIC MODELS

Part Number	Description
7010116	800 Series Motor
7631331	800 Series Pump Body
7633330	800 Series Roller Block
7018068	800 Series EPDM Squeeze Tube (T-66-E)
7018087	800 Series Viton Squeeze Tube (T-66-F)
7630330	800 Series Face Plate
7010237	900 Series Motor
7630701	900 Series Pump Body
7630731-1	900 Series Roller Block
7028662	900 Series Squeeze Tube (T-86-E)
7630712	900 Series Face Plate

SPARE PARTS—ELECTRIC DIAPHRAGM MODELS

Part Number	Description
7317323	Three Chamber Upper Housing Assembly
7317324	Three Chamber Lower Housing Assembly
7317321	Three Chamber Valve Housing Assembly EPDM
7317322	Three Chamber Valve Housing Assembly Viton
7317317	Five Chamber Upper Housing Assembly
7317320	Five Chamber Lower Housing Assembly
7317326	Five Chamber Valve Housing Assembly EPDM
7317325	Five Chamber Valve Housing Assembly Viton
1600139-01	Motor/Pump for PMPE-550V3.2, EPDM 115 VAC
1600139-02	Motor/Pump for PMPE-550V3.2, EPDM 230 VAC
1600137-01	Motor/Pump for PMPE-770V1.5, EPDM 115 VAC
1600137-02	Motor/Pump for PMPE-770V1.5, EPDM 230 VAC
1600144-01	Motor/Pump for PMPE-550V3.2, Viton 115 VAC
1600144-02	Motor/Pump for PMPE-550V3.2, Viton 230 VAC
1600135-01	Motor/Pump for PMPE-770V.4, EPDM 115 VAC
1600136-01	Motor/Pump for PMPE-770V.4, Viton 115 VAC
1600138-01	Motor/Pump for PMPE-770V1.5, Viton 115 VAC
1600138-02	Motor/Pump for PMPE-770V1.5, Viton 230 VAC
1600131-01	Motor/Pump for PMPE-770V1.5PS, EPDM 115 VAC
1600132-01	Motor/Pump for PMPE-770V1.5PS, Viton 115 VAC
1600800	Fitting, EPDM, Straight, 1/2"
1600801	Fitting, Viton, Straight, 1/2"
1600802	Fitting, EPDM, ELL, 1/2"
1600803	Fitting, Viton, ELL, 1/2"
1600804	Fitting, EPDM, Straight, 3/8"
1600805	Fitting, Viton, Straight, 3/8"
1600806	Fitting, EPDM, ELL, 3/8"
1600807	Fitting, Viton, ELL, 3/8"

EXPLODED PARTS NOMENCLATURE DIAGRAMS

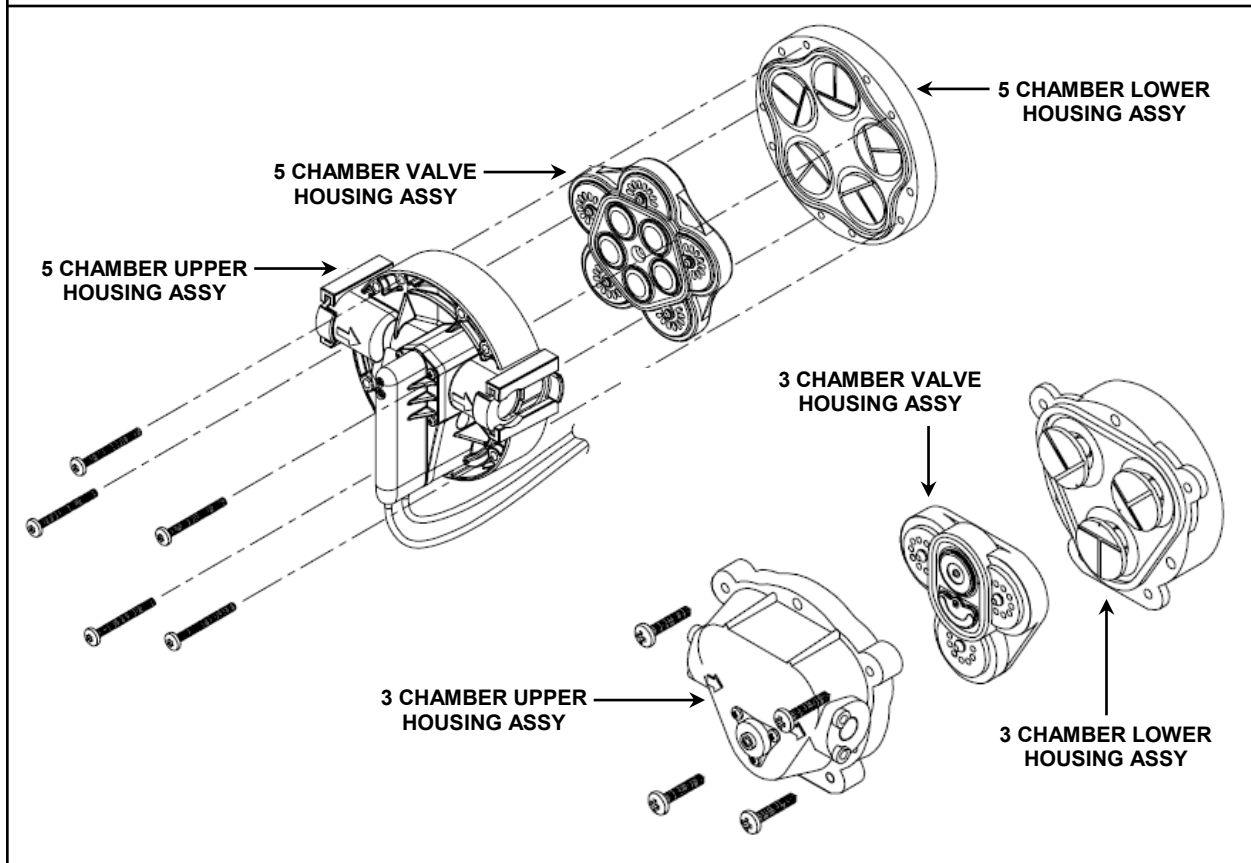
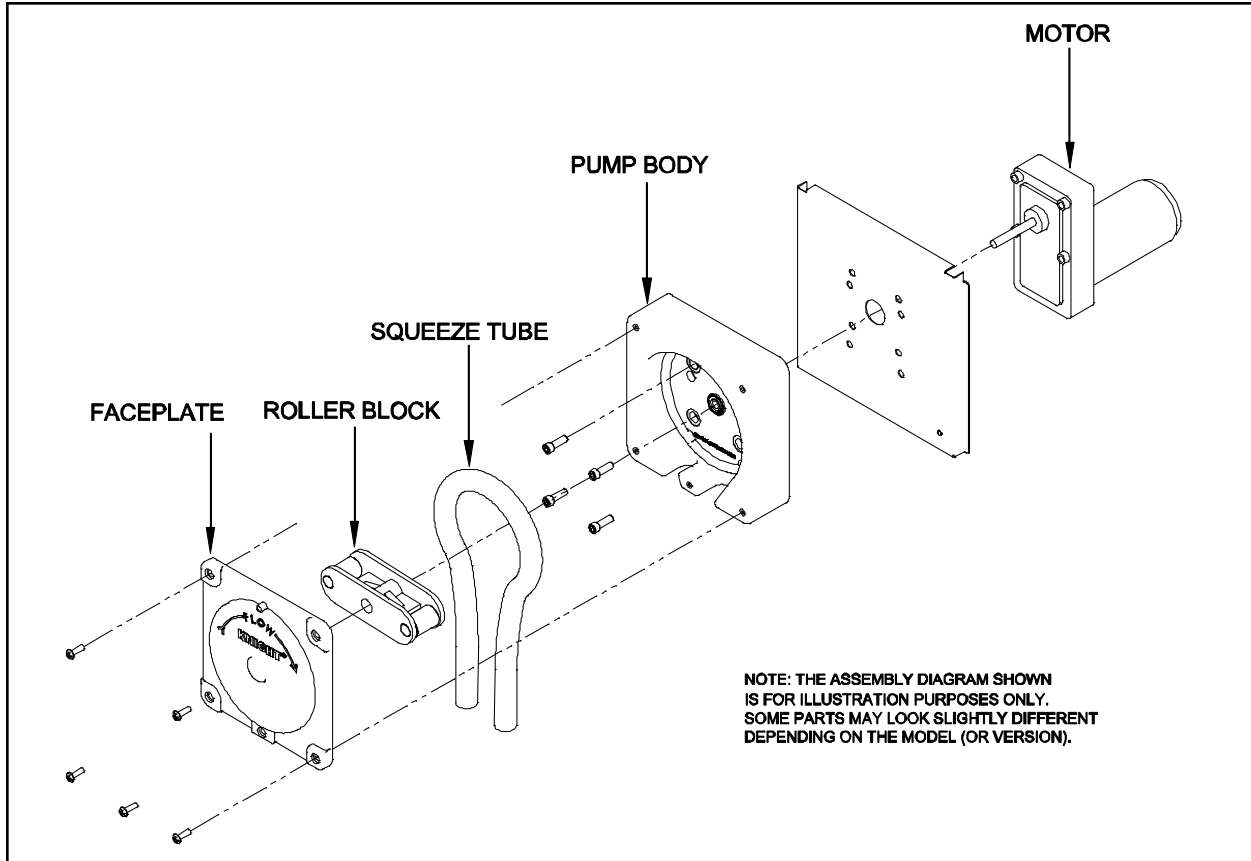

TROUBLESHOOTING—PERISTALTIC MODELS

Pump will not hold prime:

- Check for air leaks in the suction line up to the pump.
- Check for excessive roller block wear.

Pump does not trigger from signal:

- Check signal voltage and duration.
- Check pump run and delay time settings.
- Pump may be counting down a "lockout" time (if used) from a previous activation.

Pump will not turn when trying to prime, or normal activation:

- Check for loose pump motor wires.
- Check for voltage from circuit board to motor.
- Check for mechanical binding of moving parts.

Pump turns but do not dispense product:

- Check product containers.
- Check squeeze tube for wear.
- Check condition of roller and pump housing.
- Check for air leaks on suction line.
- Check for blockage from pump tube into injection point.

Pump triggers at incorrect time:

- Check supply signal input for repeat signals from control source.
- Check signal lock-out function.

MAINTENANCE—PERISTALTIC MODELS

Peristaltic pumps require a minimal amount of maintenance to achieve optimal performance. Periodically check the squeeze tube for cracks, deterioration, or swelling. The squeeze tube will typically need to be replaced about every 6 months (chemical compatibility and duty cycle can cause this interval to vary).

Applying lube to the squeeze tube once a month will extend the life of the tube, minimize wear on other contacting parts, and promote smoother pump operation. Use Knight Tube Lube (P/N 7506621) or an equivalent silicone-based lubricant.

- (1) Remove the faceplate of the pump.
- (2) Apply a thin bead of Tube Lube to the inner surface (the side that the rollers contact) of the squeeze tube between the 9 o'clock and 3 o'clock positions. Avoid getting lube near the pinch points where the bottom of the faceplate grips the tube.
- (3) Put the faceplate back on the pump.
- (4) Activate the pump under normal operation — the lubricant will be evenly distributed as the pump rotates.

TROUBLESHOOTING—ELECTRIC DIAPHRAGM MODELS

Pump does not run:

- Blown fuse inside the PMP unit.
- Tripped breaker at the power source that the PMP is connected to.
- Incorrect polarity on pump motor wiring to circuit board.

Pump will not prime/difficult to prime:

- Check for air leaks at the inlet fitting on the pump.
- Check for obstruction in the chemical suction line and also discharge line (Pump will prime only if all pressure is relieved from outlet port).
- Possible debris stuck in the diaphragms or damage to the diaphragms.
- If the pump fails to prime, pour a small amount of water into the suction port while the pump is running, then re-connect the suction hose. Once the pump is primed with water the valves/diaphragm are ready for chemical.

Low flow or low output pressure:

- Loose or broken inlet fitting on suction side of pump (causes air in the pump or in the tubing).
- Incorrect speed adjustment setting on circuit board.
- Pump motor damaged or diaphragm seals damaged.

Pump leaks:

- Diaphragm possibly damaged.
- Inlet and/or outlet fittings possibly cracked.

MAINTENANCE—ELECTRIC DIAPHRAGM MODELS

- Flushing the pump with warm water every 60—90 days will prolong the life of your pump.
- Fluctuations in power will change pump speed. Be sure your power source provides proper voltage.

TROUBLESHOOTING 4-20 MA SIGNALS—ALL MODELS

All the components in a current loop system will have an observable voltage across its terminals due to the impedance of a device. Based on this principle, any device connected to a 4-20 mA control system will show a voltage difference between its positive and negative terminal.

In the case of the PMP Plus board, a voltage difference of approximately 0.96 Volts will be observable if a 4 mA signal is present. A Voltage difference of 4.8 Volts will be observable when a 20 mA signal is present. The tables located on Pages 8-11 of the PMP Plus Manual list a control current and a corresponding Voltage that will be observed for the associated with this current.



KNIGHT, LLC
A Unit of IDEX Corporation
20531 Crescent Bay Dr.
Lake Forest, CA 92630-8825, U.S.A
Phone: (949)595-4800
Fax: (949)595-4801
www.knightequip.com

EC – DECLARATION OF CONFORMITY

Equipment Description: Chemical Dispenser Systems

Type/Model Number: PMP/PMP Plus

The signing legal authorities state that the above mentioned equipment meets the requirements for emission, immunity and safety according to.

Application of Council Directives:

Electromagnetic compatibility

(EMC) Directive 2004/108/EC (and former Directive 89/336/EEC as amended by 92/31/EEC and 93/68/EEC)

Standards to Which Conformity Is Declared: **EN 61326-1: 2006** Electrical Equipment Measurement, Control & Laboratory Use (Normal Environment)

For Information: The "Electromagnetic Test" took place at the Aegis Labs, Lake Forest, CA, U.S.A

Electrical Safety

Low Voltage Directive (LVD) 2006/95/EC (and former Directive 73/23/EEC)

Standards to Which Conformity Is Declared: **EN 61010-1 (2nd Edition)** - Safety Requirements for Electrical Equipment for Measurement, Control, and Laboratory Use - Part 1: General Requirements

For Information: The "Electrical Safety Test" took place at the CSA International, Irvine, CA, U.S.A

Signature of representative of manufacturer:

A handwritten signature in black ink that reads "Craig F. Wood".

Name: Wood, Craig

Position: Director of Engineering

Date: July 28, 2011

DISCLAIMER

Knight LLC does not accept responsibility for the mishandling, misuse, or non-performance of the described items when used for purposes other than those specified in the instructions. For hazardous materials information consult label, MSDS, or Knight LLC. Knight products are not for use in potentially explosive environments. Any use of our equipment in such an environment is at the risk of the user, Knight does not accept any liability in such circumstances.

WARRANTY

All Knight controls and pump systems are warranted against defects in material and workmanship for a period of ONE year. All electronic control boards have a TWO year warranty. Warranty applies only to the replacement or repair of such parts when returned to factory with a Knight Return Authorization (KRA) number, freight prepaid, and found to be defective upon factory authorized inspection. Bearings and pump seals or rubber and synthetic rubber parts such as "O" rings, diaphragms, squeeze tubing, and gaskets are considered expendable and are not covered under warranty. Warranty does not cover liability resulting from performance of this equipment nor the labor to replace this equipment. Product abuse or misuse voids warranty.

FOOTNOTE

The information and specifications included in this publication were in effect at the time of approval for printing. Knight LLC reserves the right, however, to discontinue or change specifications or design at any time without notice and without incurring any obligation whatsoever.

KNIGHT LLC, A Unit of IDEX Corporation (www.knightequip.com)

Knight Headquarters Tel: 949.595.4800 Fax: 949.595.4801	USA Toll Free Tel: 800.854.3764 Fax: 800.752.9518	Knight Canada Tel: 905.542.2333 Fax: 905.542.1536	Knight Europe Tel: 44.1293.615.570 Fax: 44.1293.615.585	Knight Australia Tel: 61.2.9725.2588 Fax: 61.2.9725.2025	Knight N. Asia Tel: 82.2.3481.6683 Fax: 82.2.3482.5742	Knight S. Asia Tel: 65.6763.6633 Fax: 65.6764.4020
--	--	--	--	---	---	---
