



PRO-WATCH MISTING SYSTEM INSTRUCTION MANUAL

INTRODUCTION

If you received this manual as part of the Misting Kit, please see page 5. For all other applications, continue on...

The Pro-Watch Misting System is a liquid dispenser designed to automatically spray predetermined volumes of chemicals such as deodorants and odor suppressants into trash compactors, trash bins, or any other application requiring chemical treatment. The microprocessor timer activates the peristaltic pump which pushes liquid through a spray nozzle, permitting large areas of waste to be treated.

The Pro-Watch uses an MT-300 control, capable of up to 20 separate run events per day. Each event can run for up to 16 minutes. The MT-300 also has a security feature to prevent accidental or unauthorized programming changes, and an “onboard” battery (with 5-year life) keeps the current time setting in the event of main power loss. All programmed information is saved in non-volatile memory.

INSTALLATION

APPLICATION NOTE: Do not use system in freezing temperatures.

- (1) Mount the unit on a wall using the supplied mounting bracket (customer must supply hardware to install). Choose a mounting location near both the injection point and chemical supply. CAUTION: Do not mount the unit in the direct path of steam. This can short circuit and permanently damage your system.
- (2) If applicable, connect main power wires as shown in the wiring diagram on page 3, and per local electrical codes. Failure to do so will void warranty.
- (3) Mount the spray nozzle assembly (horizontal or vertical) in the desired location. Do not remove the green protective cap from the nozzle while mounting — it prevents damage to the spray tip from tools or handling.
- (4) Install poly tubing between the pickup tube and the input (left) side of the pump’s squeeze tube. Use a hose clamp to secure poly tubing to the squeeze tube. Be sure to draw poly tubing through the end of the pickup tube.
- (5) Insert the footvalve (strainer) into the bottom of the poly tube.
- (6) Install poly tubing between the output (right) side of the pump’s squeeze tube and the elbow fitting on the spray nozzle assembly. Push the poly tubing into the elbow fitting to secure it. Use a hose clamp to secure poly tubing to the squeeze tube.
- (7) Remove the green protective cap mentioned in step 3.
- (8) To prime the pump, insert the pickup tube into the chemical container and press the “PRIME 1” button on the front cover of the system. The pump will run as long as the button is pressed.

HOW TO EASILY CALCULATE PUMP RUN TIMES

The pump dispenses about 3 ounces per minute under normal operation with the nozzle in place. The actual flow rate of the pump will vary depending on product viscosity, tubing distance, and other factors. The steps below will help you in determining the run time required to dispense the volume needed for your application.

- (1) Make sure the chemical lines (both the pickup side and output side of the pump) are fully primed.
- (2) Place a beaker or measuring cup under the spray nozzle, then hold down the PRIME 1 button for 30 seconds.
- (3) Check the volume dispensed into your container and multiply by 2 — this will determine the actual flow rate of the pump in oz/minute.
- (4) Use this flow rate to determine how long you will need the pump to run to delivery the dosage required for your application.

OPERATION NOTES

- During normal operation, the clock will display briefly when a run event starts, or while PRIME button is pressed.
- During programming, if a button is not pushed within 2 minutes, the display will disappear and the control will return to normal operation.

BUTTON FUNCTIONS

- PRGM: Steps you through the setup program.
- PRIME 1 (↓): Manually activates the pump and shows clock when not programming.
Advances numbers downward when programming.
- PRIME 2 (↑): Manually activates the solenoid (if applicable) and shows clock when not programming.
Advances numbers upward when programming.

SECURITY FEATURE — REMOVE JUMPER JP1 TO PROGRAM

To prevent unauthorized tampering, the events and time/day setting can be “secured” by placing a jumper on the JP1 pins on the back of the MT-300 circuit board. The jumper acts like a lock and key...when the MT-300 is secured (jumper on) the display will show “SECU” if the PRGM button is pressed. The PRIME buttons are not affected and will still function in their normal manner. Removing the jumper allows the MT-300 to be programmed or to change the time of day clock. Replace jumper when done programming if you wish to secure the system.

HOW TO SET THE SYSTEM

- (1) Press the PRGM button.....set the clock to the current time of day. Use ↑/↓ to set the clock (note AM/PM).
- (2) Press PRGM again.....PE 1 will be displayed. PE stands for Pump Events (“on” times) needed per day. Use ↑/↓ to set the number of pump events per day that are required. The system will activate only the number of pump events indicated by the PE #.
- (3) Press PRGM again.....E 1 will be displayed indicating that you are going to program the first event.
- (4) Press PRGM again.....pump start time will be displayed. Use ↑/↓ to set pump start time (note AM/PM).
- (5) Press PRGM again.....pump run time will be displayed. Use ↑/↓ to set the pump run time (min:sec).
- (6) Press PRGM again.....E 2 will be displayed if you selected more than 1 pump event (PE) per day. Repeat the event programming instructions above to program all pump events. After all pump events are programmed, you will return to the blank display.
- (7) To review your programming, press the PRGM button and slowly step through the program. Make changes as necessary referring to the above instructions.

Tip: If you hold down any of the buttons while programming, the numbers will scroll much faster.

Tip: If you get lost in the program, press PRGM until you return to blank display. Then repeat instructions above.

WIRING DIAGRAM

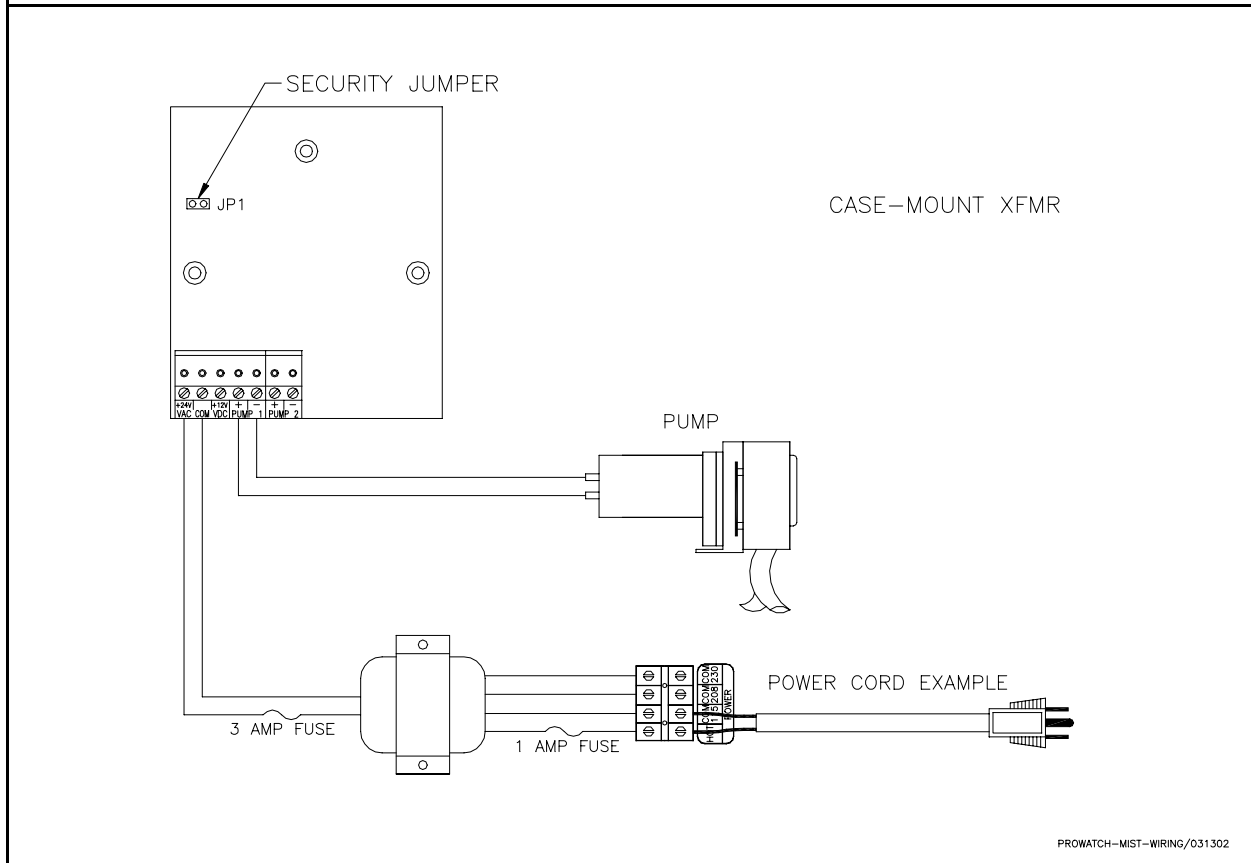
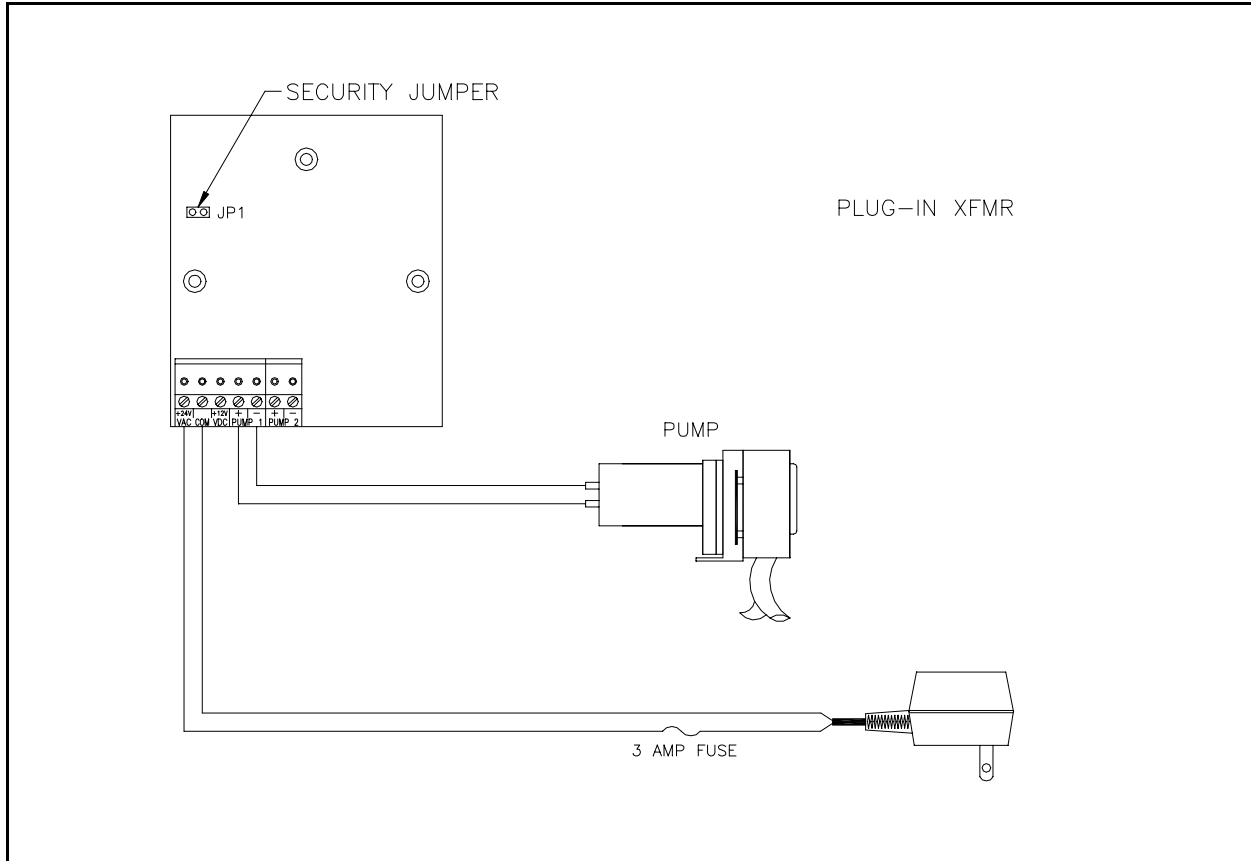

PROWATCH-MIST-WIRING/031302

SPRAY NOZZLE DIAGRAM

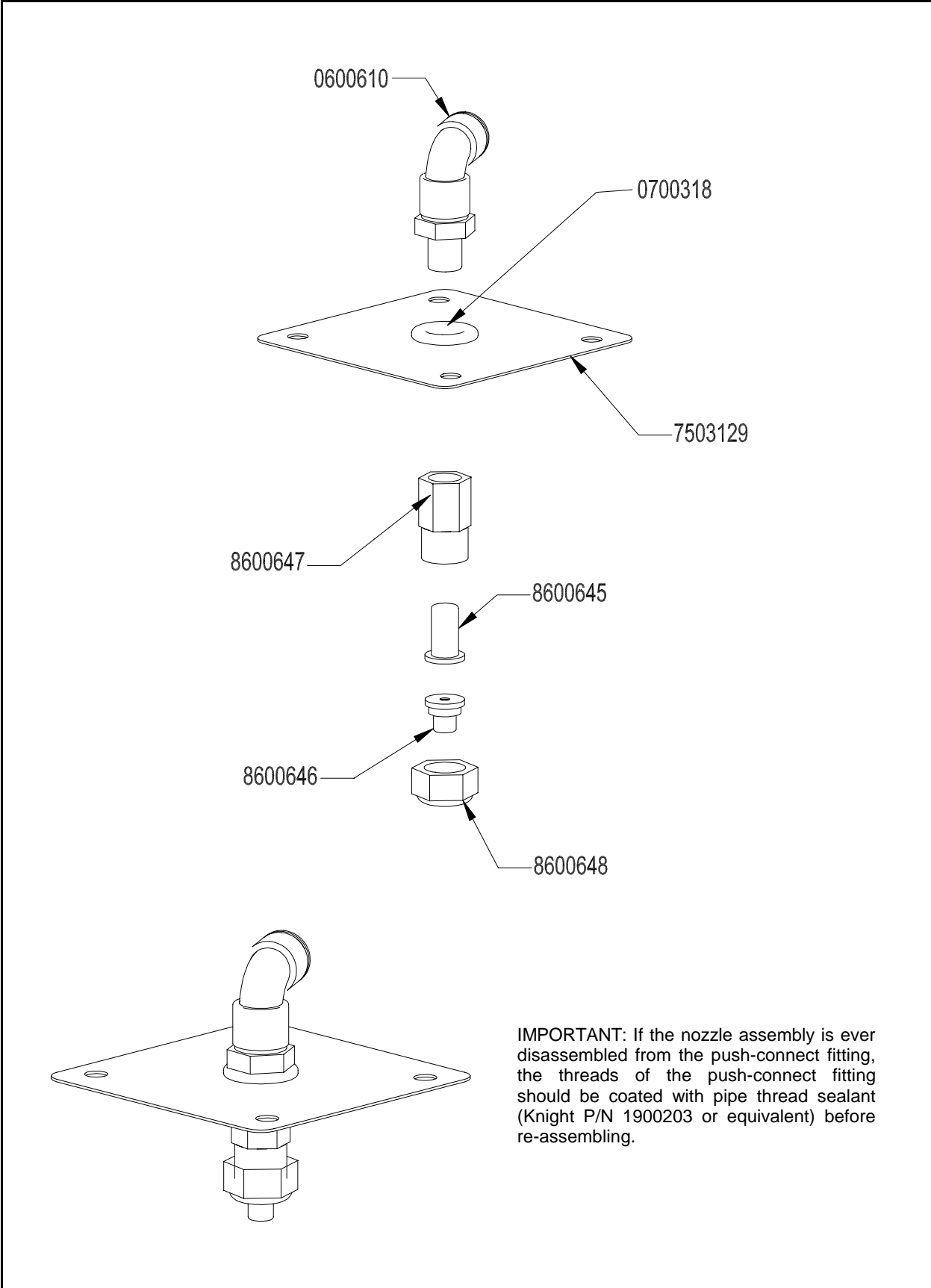

IMPORTANT: If the nozzle assembly is ever disassembled from the push-connect fitting, the threads of the push-connect fitting should be coated with pipe thread sealant (Knight P/N 1900203 or equivalent) before re-assembling.

MISTING KIT OVERVIEW

The Misting Kit includes all parts necessary to convert a standard Pro-Watch dispenser to a Misting System. Use of this kit is only recommended for Pro-Watch systems that have a transformer (internal or external) and is not intended for use with battery-operated versions.

The kit comes with a spray nozzle, a roll of 3/8" OD poly tubing, a 3/8" ID pickup tube, 2-lobe roller block assembly, T-50-T squeeze tube, hose clamps, and a footvalve. The larger poly tubing helps to improve the flow so the system can effectively generate the pressure required to spray chemical through the nozzle.

MISTING KIT INSTALLATION

- (1) If applicable, pull the pickup tube out of the chemical container and run the lines dry using the PRIME button.
- (2) Shut off power to the dispenser.
- (3) Remove the 2 outer screws and the faceplate from the pumphead.
- (4) Remove the existing squeeze tube along with the 1/4" poly tubing and 1/4" pickup tube. You can discard these parts as they will no longer be used.
- (5) Remove the existing roller block assembly from the pumphead and install the 2-lobe roller provided in the kit.
- (6) Install the T-50-T squeeze tube included with the kit. Pinch the tube with your fingers to help press it into place between the rollers and pump body.
- (7) Apply a light coating of Knight Tube Lube (or equivalent silicone-based lubricant) to the T-50-T squeeze tube. Avoid getting lube near the pinch points where the bottom of the faceplate grips the tube.
- (8) Put the faceplate and screws back on the pumphead. Be careful when tightening the screws to avoid cracking the faceplate.
- (9) Mount the spray nozzle assembly (horizontal or vertical) in the desired location. Do not remove the green protective cap from the nozzle while mounting — it prevents damage to the spray tip from tools or handling.
- (10) Install the provided 3/8" poly tubing between the pickup tube and the input (left) side of the pump's squeeze tube. Use a hose clamp to secure poly tubing to the squeeze tube. Be sure to draw poly tubing through the end of the pickup tube.
- (11) Insert the footvalve (strainer) into the bottom of the poly tube.
- (12) Install the provided 3/8" poly tubing between the output (right) side of the pump's squeeze tube and the elbow fitting on the spray nozzle assembly. Push the poly tubing into the elbow fitting to secure it. Use a hose clamp to secure poly tubing to the squeeze tube.
- (13) Remove the green protective cap mentioned in step 9, then turn the power back on.
- (14) To prime the pump, insert the pickup tube into the chemical container and press the "PRIME 1" button on the front cover of the system. The pump will run as long as the button is pressed.

PROPER SPRAY NOZZLE PERFORMANCE

- The tip projects a fixed spray pattern and does not require any adjustments.
- Because the spray nozzle requires suitable pressure to work properly, it is very important to ensure that there are no air leaks in the chemical line between the pump and the spray nozzle. Air leaks can hinder the line pressure which may result in the chemical "dripping" from the nozzle rather than spraying.

TROUBLESHOOTING

❑ **No power:**

Check the in-line fuse to the power transformer.

Check the voltage at the transformer.

Check input terminals on board for loose screws and correct input voltage. Refer to the wiring diagram for voltage input terminals.

❑ **Pump will not activate:**

Check pump output terminals for loose screws and disconnected wires.

Check for proper voltage across motor windings.

Check for obstruction in pump head.

❑ **Too much chemical:**

Check the number of events programmed.

Check the run time for each programmed event.

❑ **Too little chemical:**

Check the number of events programmed.

Check the run time for each programmed event.

Check for obstruction in pump head.

❑ **Pump runs too slowly:**

Check roller block for binding.

Check voltage (24 VDC applied to the pump motor terminals will result in the highest speeds).

Check for lubrication on squeeze tube.

❑ **Pump will not shut off:**

Check if an event is running.

Check for stuck prime switch.

Try shutting off main power (unplugging or disconnecting xfmr) for a few minutes.

Possible damaged circuit board.

❑ **Loss of pump prime:**

Check pickup line for any holes or air leaks.

Check squeeze tubing in pump for any cracks or pin holes.

Check tubing for deterioration.

❑ **Spray nozzle drips or does not spray:**

Check for obstruction in pump head, or problem with squeeze tube that could be blocking flow of chemical to spray nozzle assembly.

Check for air leaks that could be reducing line pressure to the spray nozzle.

Check for damage to the spray nozzle.

NOTES:

DISCLAIMER

Knight Inc. does not accept responsibility for the mishandling, misuse, or non-performance of the described items when used for purposes other than those specified in the instructions. For hazardous materials information consult label, MSDS, or Knight Inc.

WARRANTY

All Knight controls and pump systems are warranted against defects in material and workmanship for a period of ONE year. All electronic control boards have a TWO year warranty. Warranty applies only to the replacement or repair of such parts when returned to factory with a Knight Return Authorization (KRA) number, freight prepaid, and found to be defective upon factory authorized inspection. Bearings and pump seals or rubber and synthetic rubber parts such as "O" rings, diaphragms, squeeze tubing, and gaskets are considered expendable and are not covered under warranty. Warranty does not cover liability resulting from performance of this equipment nor the labor to replace this equipment. Product abuse or misuse voids warranty.

KNIGHT INC. A Unit of IDEX Corporation

World Headquarters: 20531 Crescent Bay Drive, Lake Forest, CA 92630-8825 (USA) TEL: 949-595-4800, FAX: 949-595-4801, www.knightequip.com

Atlanta Branch: 415 Gees Mill Business Court NE, Suite 200 Conyers, GA 30013 USA TEL: 770-760-8777 FAX: 770-761-0199	Toronto Branch: 2880 Argentia Road, Unit 6 Mississauga, Ontario L5N 7X8 Canada TEL: 905-542-2333 FAX: 905-542-1536	London Branch: #15 Brunel Centre Newton Road, Crawley West Sussex UK RH10 9TU TEL: 44-1293-615570 FAX: 44-1293-615585	Sydney Branch: Unit 28, 317-321 Woodpark Rd., Smithfield NSW Australia 2164 TEL: 61-29-725-2588 FAX: 61-29-725-2025	Amsterdam Branch: Marssteden 68 7547 TD Enschede The Netherlands TEL: 31-53-428-58-00 FAX: 31-53-428-58-09	Spain Branch: Port Ginesta, Local 210 08860 Sitges Barcelona Spain TEL: 34-936-342-130 FAX: 34-936-643-477
---	---	--	--	---	---