



UDP-100S / UPP-100S Instruction Manual

TABLE OF CONTENTS

UDP-100S Installation	2
UDP-100S Pump Connections	2
UDP-100S Operation.....	2
UPP-100S Installatiion.....	3
UPP-100S Pump Connections	3
UPP-100S operation.....	3
Wiring Diagram.....	9
Assembly Diagram	10
Warranty Information.....	6
Knight Locations	6



CAUTION: The UDP /UPP Series system has high voltage connected to the transformer always disconnect main power when servicing the unit.

UDP-100S INSTALLATION

- (1) Mount the unit on a wall in a convenient location near the dishwasher, the DataPlus unit that will control the UDP-100S, and not more than three feet from the final rinse line. **Ensure that the distance from the bottom of the UDP-1000S to the top of the chemical container will be at least 12"**. A mounting bracket is available for mounting the unit on top of the dishwasher if desired. NOTE: Mounting the unit on the side, on the back, or on the vents of the dishwasher may cause thermal overload and damage or hinder the performance of the unit. Do NOT mount the unit in the direct path of steam. This can short circuit and permanently damage the unit.
- (2) Remove power from the DataPlus unit that will control the UDP-100S.
- (3) Install the 4-conductor cable from the UDP-100S to the DataPlus circuit board (see installation drawing).

UDP-100S PUMP CONNECTIONS

- (1) Install 1/4" tube injection fitting into the side or bottom of the dishwasher rinse line between the rinse solenoid valves and the rinse jets. Drill a 11/32" hole and tap to 1/8" NPT. Use of a saddle clamp may be desired on copper rinse line for better support. Saddle clamps can be used if required.
- (2) Install 1/4" O.D. poly tubing between the discharge (right) tube side of the peristaltic pump and the injection fitting using the 1/4" poly compression nuts.
- (3) Install 1/4" O.D. poly tubing between the suction (left) tube side and the pickup tube provided. Be sure to draw tubing through the end of the pickup tube.

UDP-100S OPERATION

Control of the pump will be performed by the DataPlus unit that the pump is connected to — refer to the DataPlus Programming Manual for detailed implementation instructions of the UDP-100S.

As a reminder, remember to remove the jumper over the LOW SAN terminals on the DataPlus board or the low level lights and alarms will NOT activate.

UPP-100S INSTALLATION

- (1) Mount the unit on a wall in a convenient location near the dishwasher, the device that will control the UPP-100S, and not more than three feet from the final rinse line. A mounting bracket is available for mounting the unit on top of the dishwasher if desired. NOTE: Mounting the unit on the side, on the back, or on the vents of the dishwasher may cause thermal overload and damage or hinder the performance of the unit. Do NOT mount the unit in the direct path of steam. This can short circuit and permanently damage the unit.
- (2) Check the voltage of the device that will control the UPP-100S.; the variable speed pump motor requires a 0-24 VDC source. Application of incorrect voltage will permanently damage the unit and is not covered under warranty.
- (3) Remove power from the device that will control the UPP-100S.
- (4) Connect the motor leads to the device that will be controlling the UPP-100S.

UPP-100S PUMP CONNECTIONS

- (1) Install 1/4" tube injection fitting into the side or bottom of the dishwasher rinse line between the rinse solenoid valves and the rinse jets. Drill a 11/32" hole and tap to 1/8" NPT. Use of a saddle clamp may be desired on copper rinse line for better support. Saddle clamps can be used if required.
- (2) Install 1/4" O.D. poly tubing between the discharge (right) tube side of the peristaltic pump and the injection fitting using the 1/4" poly compression nuts.
- (3) Install 1/4" O.D. poly tubing between the suction (left) tube side and the pickup tube provided. Be sure to draw tubing through the end of the pickup tube.

UPP-100S OPERATION

Control of the pump will be performed by the device that the pump is connected to — refer to the instructions provided for the device for detailed implementation instructions of the UPP-100S.

WIRING DIAGRAM UDP-100S

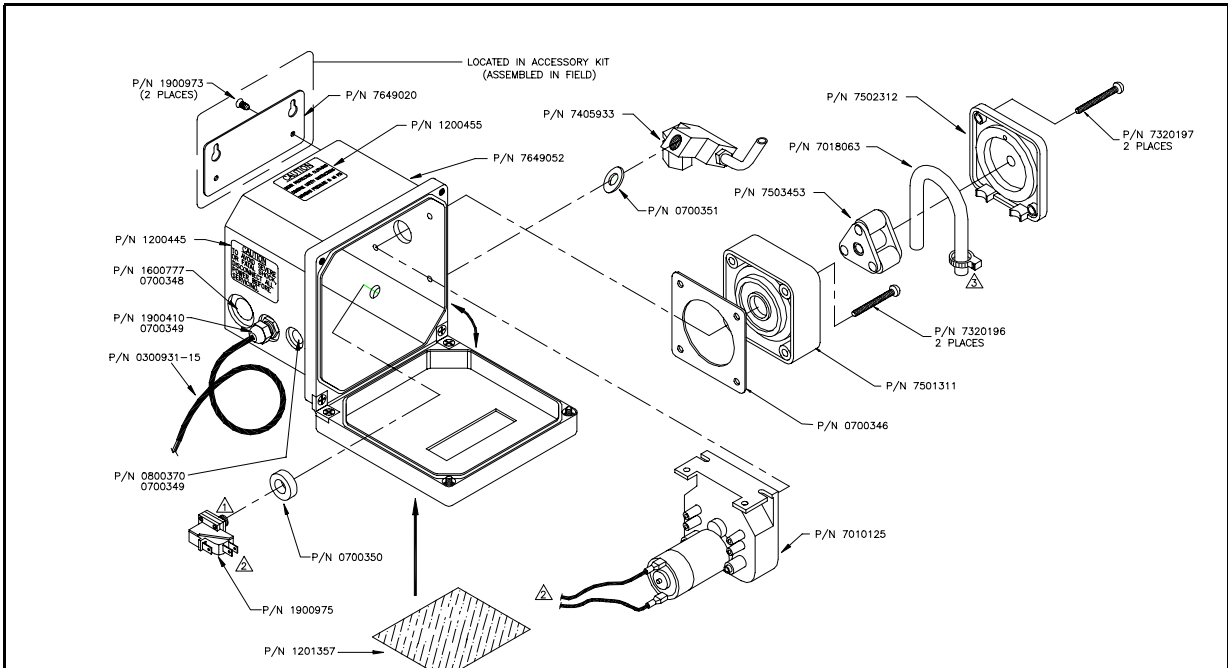

- ⚠ SECURE SQUEEZE TUBE TO BARB ON TEE ASSEMBLY USING A CABLE TIE, P/N 0300121.
- ⚠ REFER TO DRAWING # 1320 FOR WIRING DIAGRAM.
- ⚠ WRAP THREADS OF SWITCH WITH 3-5 TURNS OF TEFLON TAPE, AND TIGHTEN SWITCH TO TEE ASSEMBLY BY TURNING TEE ASSEMBLY WHILE HOLDING SWITCH IN PLACE. TURNING OF SWITCH BACK AND FORTH, MAYBE NECESSARY TO SUFFICIENTLY TIGHTEN TEE ASSEMBLY TO SWITCH.

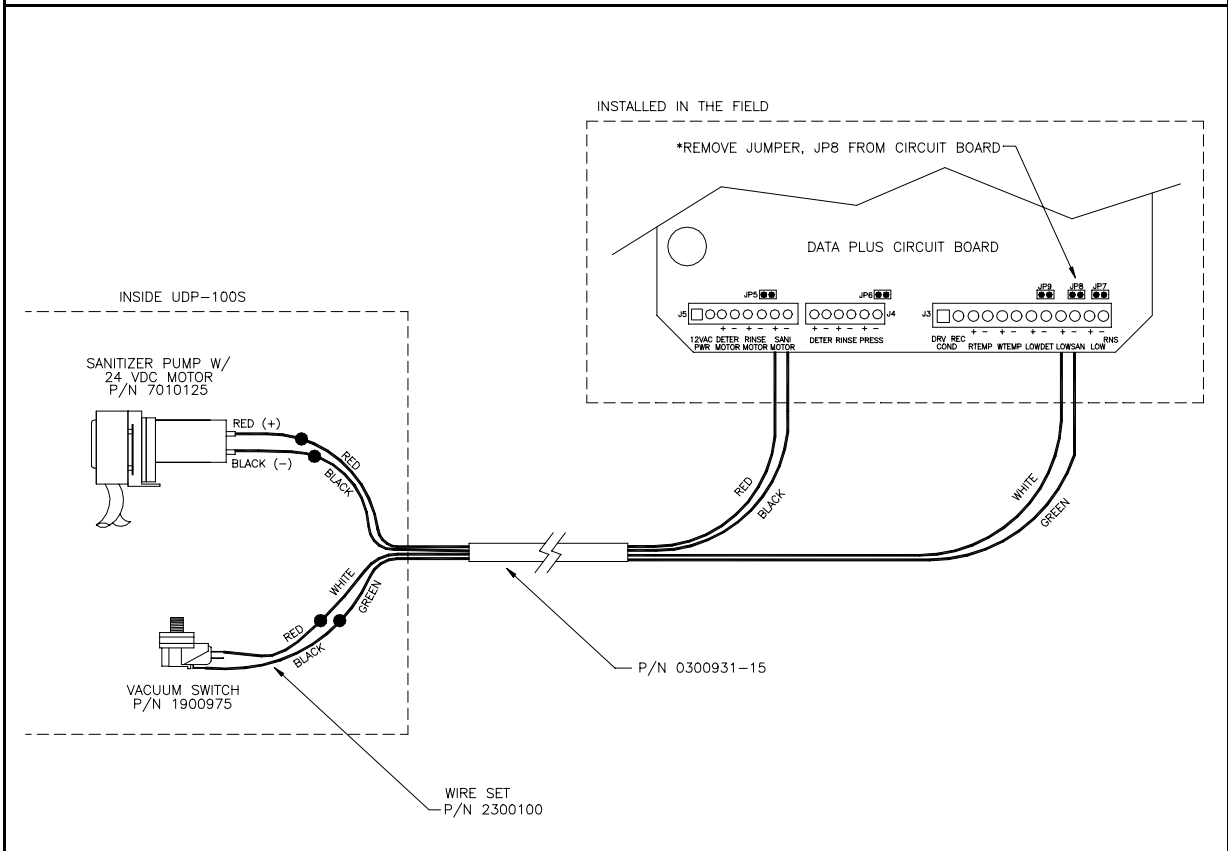

WIRING DIAGRAM UPP-100S

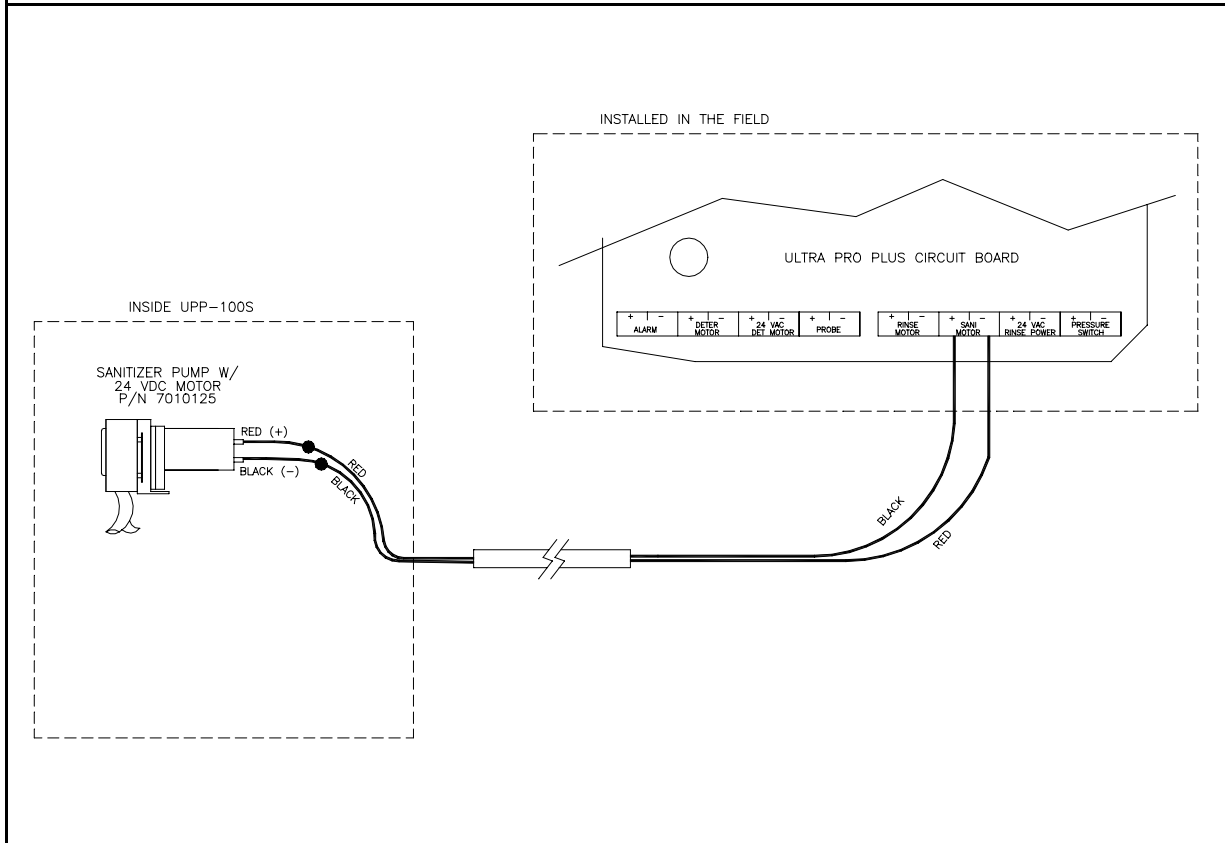
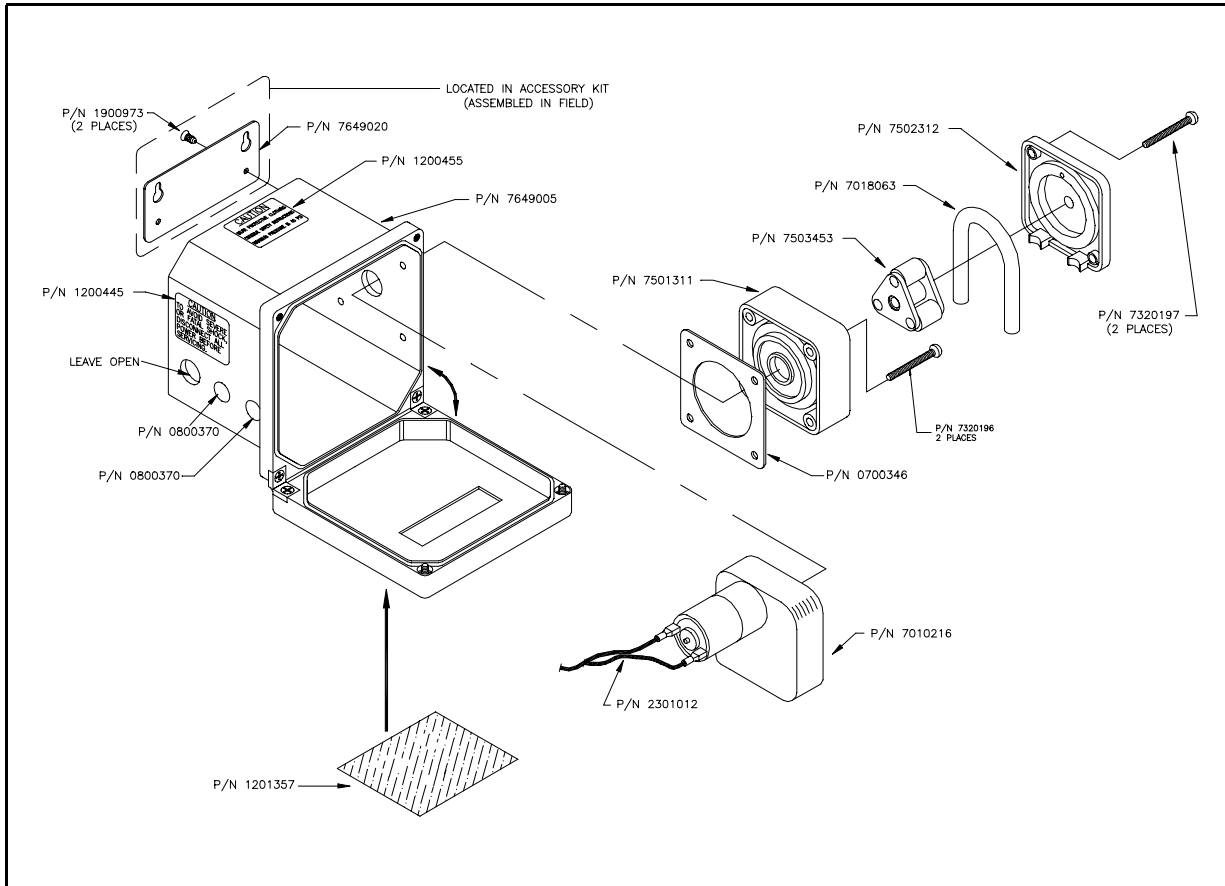

NOTE

DISCLAIMER

Knight Inc. does not accept responsibility for the mishandling, misuse, or non-performance of the described items when used for purposes other than those specified in the instructions. For hazardous materials information consult label, MSDS, or Knight Inc.

WARRANTY

All Knight controls and pump systems are warranted against defects in material and workmanship for a period of ONE year. All electronic control boards have a TWO year warranty. Warranty applies only to the replacement or repair of such parts when returned to factory with a Knight Return Authorization (KRA) number, freight prepaid, and found to be defective upon factory authorized inspection. Bearings and pump seals or rubber and synthetic rubber parts such as "O" rings, diaphragms, squeeze tubing, and gaskets are considered expendable and are not covered under warranty. Warranty does not cover liability resulting from performance of this equipment nor the labor to replace this equipment. Product abuse or misuse voids warranty.

KNIGHT INC. A Unit of IDEX Corporation

World Headquarters:
20531 Crescent Bay Dr.
Lake Forest, CA
92630-8825 USA
TEL: (949) 595-4800
FAX: (949) 595-4801

Atlanta Branch:
8111 Technology Dr. NE
Covington, GA
30014 USA
TEL: (770) 787-9400
FAX: (770) 787-1155

Toronto Branch:
2880 Argentia Road, Unit 6
Mississauga, Ontario
L5N 7X8 Canada
TEL: (905) 542-2333
FAX: (905) 542-1536

London Branch:
#15 Brunel Centre
Newton Road, Crawley
West Sussex UK RH102UB
TEL: (44) 1293-615570
FAX: (44) 1293-615585

Sydney Branch:
Unit 28, 317-321
Woodpark Rd., Smithfield
NSW Australia 2164
TEL: 61-29-725-2588
FAX: 61-29-725-2025

Amsterdam Branch:
Marssteden 68
7547 TD Enschede
The Netherlands
TEL: 31-53-428-58-00
FAX: 31-53-428-58-09